

ARL-5050YXAT 1W Yellow

Features

- Highest luminous flux
- Super energy efficiency
- Long Lifetime Operation
- Superior ESD protection
- Superior UV Resistance

Applications

- Read lights (car, bus, aircraft)
- Portable (flashlight, bicycle)
- Bollards / Security / Garden
- Traffic signaling / Beacons
- In door / Out door Commercial lights
- Automotive Ext

Outline Dimension

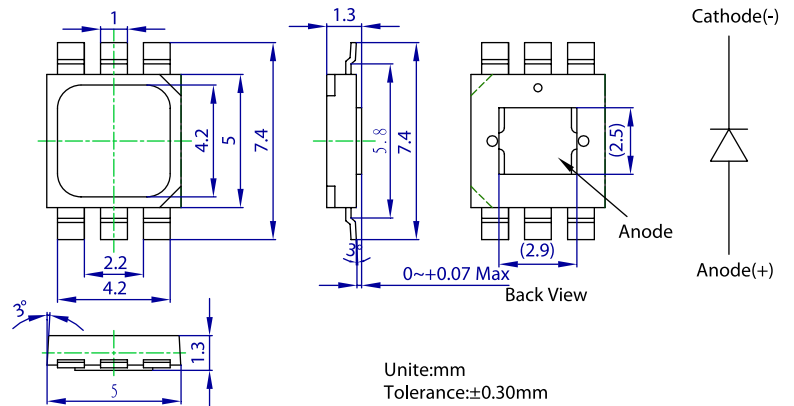

Directivity

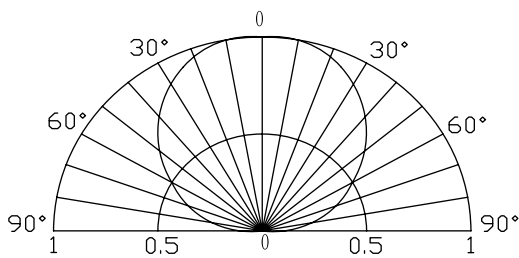

Forward Operating Current (DC)

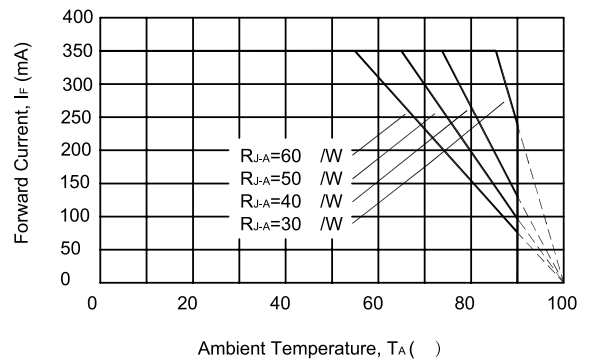

Absolute Maximum Rating

Item	Symbol	Value	Unit
DC Forward Current	IF	400	mA
Pulse Forward Current*	IFP	500	mA
Reverse Voltage	VR	5	V
Power Dissipation	PD	1200	mW
Operating Temperature	Topr	-30 ~ +85	°C
Storage Temperature	Tstg	-40 ~ +100	°C
Lead Soldering Temperature	Tsol	260°C / 5 sec	

*Pulse width Max.10ms Duty ratio max 1/10

Electrical / Optical Characteristics at TA=25°C

Item	Symbol	Condition	Min.	Typ.	Max.	Unit
DC Forward Voltage	VF	IF=350mA	2.0	2.5	3.0	V
DC Reverse Current	IR	VR=5V	-	-	10	μA
Domi. Wavelength	λD	IF=350mA	585	590	595	nm
Luminous Flux	Φv	IF=350mA	40	50	-	lm
50% Power Angle	2θ1/2	IF=350mA	-	120	-	deg

Note: Don't drive at rated current more than 5s without heat sink for Tops 1 emitter series.