

ARPJ-LAP80700 (56W, 700mA PFC)

Application

- Constant current mode power supply
- Universal AC input / Full range
- Fully encapsulated with IP67 level
- Protections: Short circuit / Over current
- Built-in active PFC function



Specification

MODEL		ARPJ-LAP80700
OUTPUT	DC VOLTAGE	80V
	DC VOLTAGE RANGE	40-80V
	CURRENT RANGE	700mA ±5%
	RATED POWER	56W
	RIPPLE & NOISE (max.)	5Vp-p
	VOLTAGE TOLERANCE	±3.0%
	LINE REGULATION	±1.0%
	LOAD REGULATION	±2.0%
	SETUP, RISE TIME	1500ms,250ms/230VAC 3000ms,250ms/115ac at full load
INPUT	VOLTAGE RANGE	100-240VAC
	FREQUENCY RANGE	47~63Hz
	EFFICIENCY(Typ.)	88% full load
	POWER FACTOR	PF>0.9/230VAC PF>0.95/115VAC at full load
	AC CURRENT(at full load)	1.2A/100AC 0.6A/240AC
	INRUSH CURRENT (max.)	COLD STAT 70A/230VAC
	LEAKAGE CURRENT	0.5mA/240VAC
PROTECTION	OVER CURRENT	Above 105% rated output power. Protection type: Hiccup mode, recovers automatically after fault condition is removed.
	OVER TEMPERATURE	Tj 140°C typically(U1) Detect on main control IC Protection type: Hiccup mode, recovers automatically after temperature goes down
ENVIRONMENT	WORKING TEMP.	-20~+50°C
	WORKING HUMIDITY	20~90% RH non-condensing
	STORAGE TEMP, HUMIDITY	-40~+80°C, 10~95% RH
	TEMP.COEFFICIENT	±0.03%/°C (0°C~50°C)
	VIBRATION	10 ~ 500Hz, 2G 10min./1cycle, period for 60min. each along X,Y, Zaxes
SAFETY & EMC	SAFETY STANDARDS	Design refer to UL1310 Class 2,TUV EN60950-1, EN61347-2-13, CAN/CSA C22.2 No. 223-M91, meet IP67
	WITHSTAND VOLTAGE	I/P-O/P:3KVAC
	ISOLATION RESISTANCE	I/P-O/P:>100MOhms / 500VDC / 25~70%RH
	EMI CONDUCTION & RADIATION	Compliance to EN55022 (CISPR22) Class B
	HARMONIC CURRENT	Compliance to EN61000-3-2,-3
	EMS IMMUNITY	Compliance to EN61000-4-2,3,4,5,6,8,11; ENV50204,EN55024, light industry level , criteria A
DIMENSION	162*42.5*30mm (L*W*H)	

Mechanical Specification

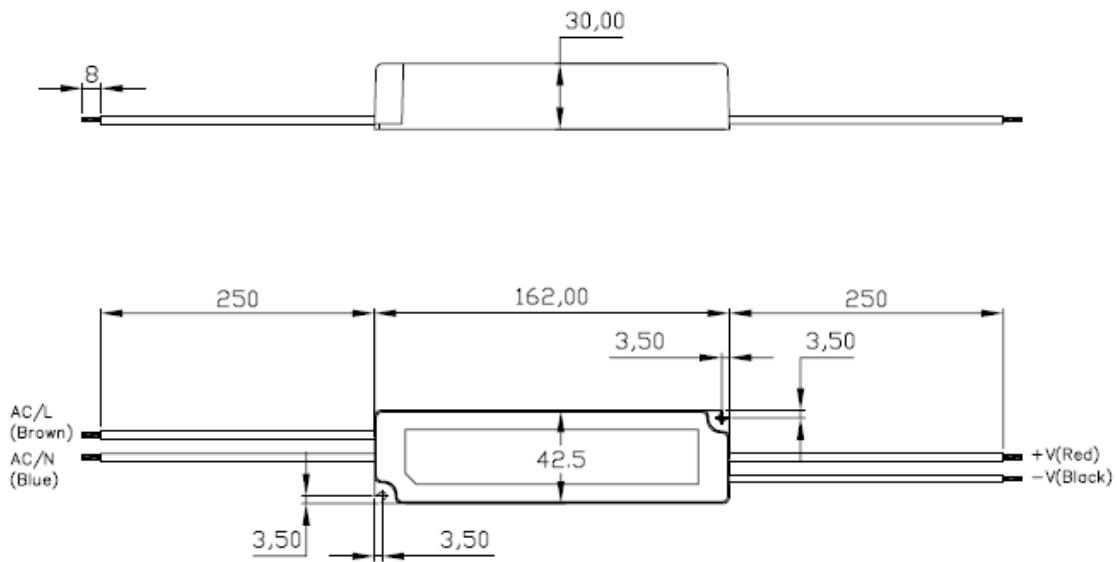

Block Diagram

