

ARPJ-LAY80350 (28W, 350mA, PFC)

Features:

- Constant current mode power supply
- Universal AC input / Full range
- Fully encapsulated with IP67 level
- Protections: Short circuit / Over current
- Built-in active PFC function



Specification:

OUTPUT	DC VOLTAGE	80V
	DC VOLTAGE RANGE	40-80V
	CURRENT RANGE	350mA ±5%
	RATED POWER	25.0W
	RIPPLE & NOISE (max.)	5Vp-p
	VOLTAGE TOLERANCE	±3.0%
	LINE REGULATION	±1.0%
	LOAD REGULATION	±2.0%
SETUP,RISE TIME	1500ms,250ms/230VAC 3000ms,250ms/115ac at full load	
INPUT	VOLTAGE RANGE	100-240VAC
	FREQUENCY RANGE	47~63Hz
	EFFICIENCY(Typ.)	86% full load
	POWER FACTOR	PF>0.9/230VAC at full load
	AC CURRENT(at full load)	0.6A/100VAC 0.3A/240VAC
	INRUSH CURRENT (max.)	COLD STAT 70A/240VAC
LEAKAGE CURRENT	0.5mA/240VAC	
PROTECTION	OVER CURRENT	Above 105% rated output power. Protection type: Hiccup mode, recovers automatically after fault condition is removed.
	OVER TEMPERATURE	Tj 140°C typically(U1) Detect on main control IC Protection type: Hiccup mode, recovers automatically after temperature goes down
ENVIRONMENT	WORKING TEMP.	-40~+50°C
	WORKING HUMIDITY	20~90% RH non-condensing
	STORAGE TEMP., HUMIDITY	-40~+80°C, 10~95% RH
	TEMP.COEFFICIENT	±0.03%/°C (0~50°C)
SAFETY & EMC	VIBRATION	10 ~ 500Hz, 2G 10min./1cycle, period for 60min. each along X,Y,Z axes
	SAFETY STANDARDS	Design refer to UL1310 Class 2,TUV EN60950-1, EN61347-2-13, CAN/CSA C22.2 No. 223-M91, meet IP67
	WITHSTAND VOLTAGE	I/P-O/P:3KVAC
	ISOLATION RESISTANCE	I/P-O/P:>100M Ohms / 500VDC / 25~70% RH
	EMI CONDUCTION & RADIATION	Compliance to EN55022 (CISPR22) Class B
SAFETY & EMC	HARMONIC CURRENT	Compliance to EN61000-3-2,-3
	EMS IMMUNITY	Compliance to EN61000-4-2,3,4,5,6,8,11; ENV50204, EN55024, light industry level, criteria A
DIMENSION		φ96*32mm (L*W*H)

Mechanical Specification:

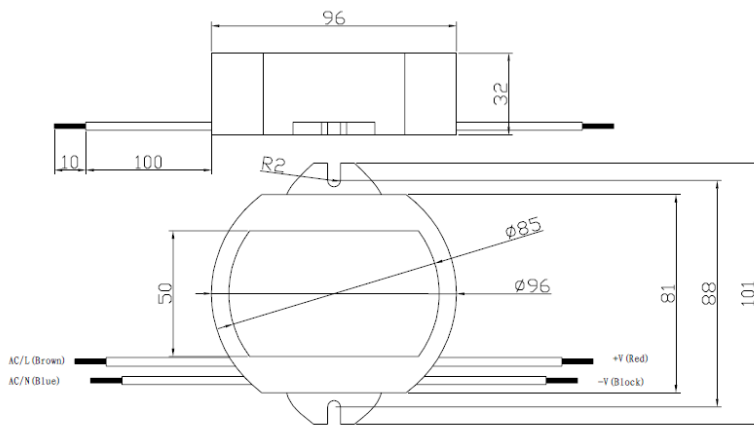

Block Diagram:

