

ARPL-10W White 6000K

FEATURES

- Long operating life
- Highest flux
- Wide range of colors:2500K-25000K
- More energy efficient than incandescent and most halogen lamps
- Low voltage DC operated
- Cool beam, safe to the touch
- Instant light (less than 100ns)
- Fully dimmable
- No UV
- Superior ESD protection
- Eutectic die bonding
- RoHS compliant

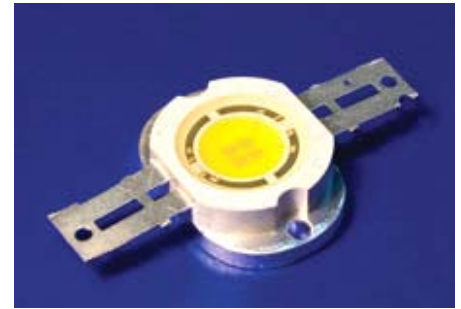

PACKAGE DIMENSIONS

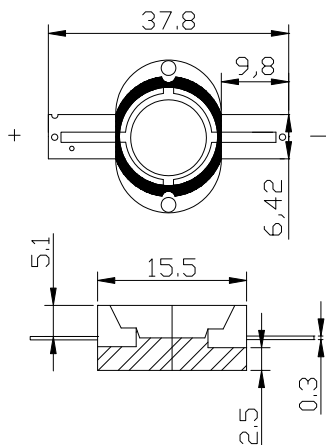

APPLICATIONS

- Reading lights (car, bus, aircraft)
- LCD Backlights/light Guides
- Fiber optic alternative / Decorative / Entertainment
- Mini-accent / Up lighters/Down lighters / Orientation
- Indoor / Outdoor commercial and Residential Architectural
- Cove / Under shelf/Task
- Bollards / Security/Garden
- Portable (flashlight, bicycle)
- Edge-lit signs (Exit, point of sale)
- Automotive Exit (Stop-Tail-Turn, CHMSL, Mirror Side Repeat)
- Traffic signaling / Beacons / Rail Crossing and Wayside

Absolute Maximum Rating at TA=25°C

Parameter	Symbol	Absolute Maximum Rating	Unit
Forward Current	IF	1.6	A
Peak Forward Current*	IFP	1.7	A
Reverse Voltage	VR	5	V
Power Dissipation	PD	10	W
Electrostatic discharge	ESD	±4500	V
Operation Temperature	TOPR	-40~+80	°C
Storage Temperature	TSTG	-40~+100	°C
Lead Soldering Temperature*	TSOL	Max. 260°C for 3sec Max.	
Storage Temperature	Tstg	-40~+80 °C	

*IFP Conditions Pulse Width≤10msec duty≤1/10

* All high power emitter LED products mounted on aluminum metal-core printed circuit board, can be lighted directly, but we do not recommend lighting the high power products for more than 5 seconds without a appropriate heat dissipation equipment.

* The LED of this a series can lead the heat reflux of 250 Celsius degrees Han but be free from damage.

Typical Electrical / Optical Characteristics at TA=25°C

Parameter	Symbol	Condition	Min	Typ	Max	Unit
Forward Voltage	V _F	I _F =1.6A	--	8	--	V
Reverse Current	I _R	V _R =5V	---	---	50	uA
50% Power Angle	2θ _{1/2}	I _F =1.6A	110	--	140	deg
Luminous Intensity	φ _V	I _F =1.6A	260	--	450	lm
Recommend Forward Current	I _F	I _F =40mA	--	1.6	--	A
Chromaticity	T _c	I _F =1.6A	5000	---	10000	K
White Color Region	---					
Chromaticity Coordinates	X=---			Y=---		

RADIATION PATTERN

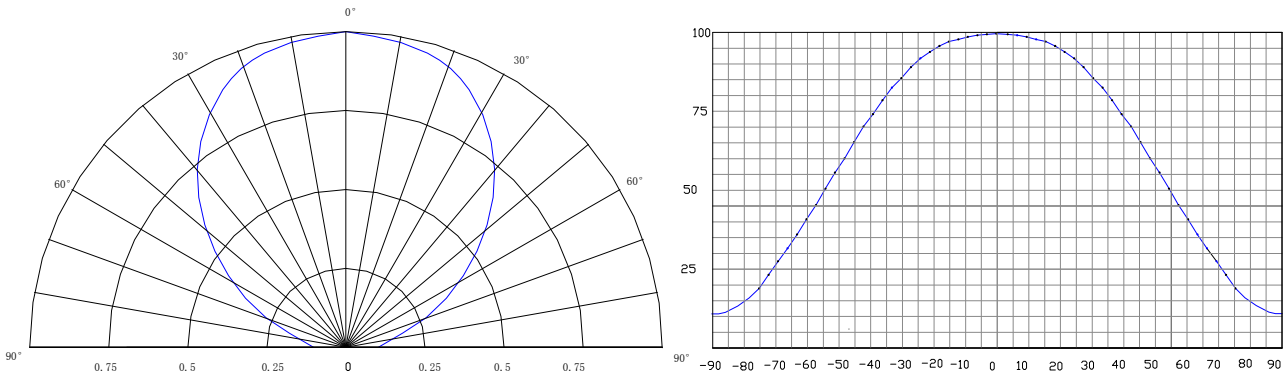

TYPICAL OPTICAL/ELECTRICAL CHARACTERISTICS CURVES (T_J=25°C Unless Otherwise Noted)

