

ARPL-3W RED (140°, RER3E)

Features

- Long operating life
- Highest flux
- Available in Blue
- Lambertian radiation pattern
- More energy efficient than incandescent and most halogen lamps
- Low voltage DC operated
- Cool beam, safe to the touch
- Instant light (less than 100ns)
- Fully dimmable
- No UV
- Superior ESD protection
- Eutectic die bonding
- RoHS compliant

Applications

- Reading lights (car, bus, aircraft)
- LCD Backlights/ light Guides
- Fiber optic alternative/ Decorative / Entertainment
- Miniaccent/ Up lighters/Down lighters/ Orientation
- Indoor/Outdoor commercial and Residential
- Architectural Cove/Under shelf/ Task
- Bollards/ Security/ Garden
- Portable (flashlight, bicycle)
- Edgelit signs (Exit, point of sale)
- Automotive Exit (StopTailTurn, CHMSL, Mirror Side Repeat)
- Traffic signaling / Beacons / RailCrossing and Wayside

Radiation Pattern

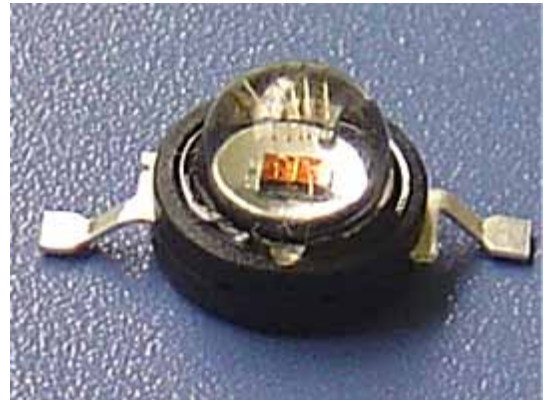
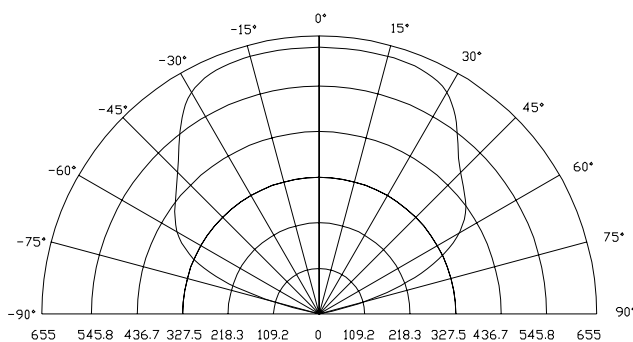

Package Dimensions

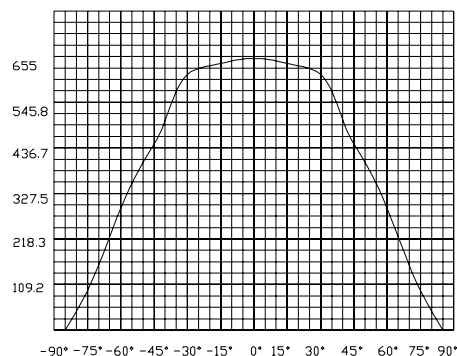
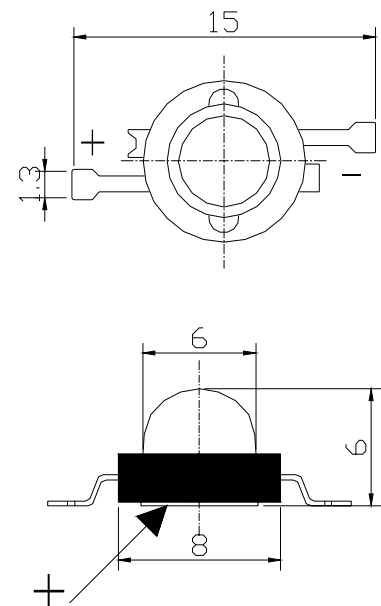

Typical Optical/ Electrical Characteristics @TJ=25°C

Item	Symbol	Condition	Min.	Typ.	Max.	Unit
Forward Voltage	VF	IF=800mA	2.0		2.8	V
Reverse Current	IR	VR=5v			50	uA
50% Power Angle	2θ1/2	IF=800mA	110		140	deg
Luminous Intensity	φV	IF=800mA	30.6		51.7	lm
Recommend Forward Current	IF			800		mA
Wave Length	λd	IF=800mA	620		630	nm
Thermal Resistance, Junction to Case	RJP	IF=800mA		15		°C/W

Notes:

- 1.Tolerance of measurement of forward voltage±0.1V.
- 2.Tolerance of measurement of peak Wavelength±2.0nm.
- 3.Tolerance of measurement of luminous intensity±15%.

Absolute Maximum Rating

Item	Symbol	Absolute Maximum Rating	Unit
Forward Current	IF	800	mA
Peak Forward Current*	IFP	1000	mA
Reverse Voltage	VR	5	V
Power Dissipation	PD	3000	mW
Electrostatic discharge	ESD	±4500	V
Operation Temperature	TOPR	40~+80	°C
Storage Temperature	TSTG	40~+100	°C
Lead Soldering Temperature*	TSOL	Max. 260°C for 3sec Max.	

Notes:

- *IFP Conditions ≤ Pulse Width ≤10msec duty≤1/10
- * All high power emitter LED products mounted on aluminum metalcore printed circuit board, can be lighted directly, but we do not recommend lighting the high power products for more than 5 seconds without a appropriate heat dissipation equipment.
- *Ref-low, wave peak and soakstannum soldering etc.is not suitable for this products.
- *Suggest to solder it by professional high power LED soldering machine.
- *Can use invariabletemperature searingiron with soldering condition : ≤260 degree less than 3 seconds.

Typical Optical/Electrical Characteristics Curves (T_J=25°C Unless Otherwise Noted)

