

ARPV-16-12036 (12V, 3A, 36W)

1 Scope

This is the engineering specification of ARPV-16-12036 36Watt power AC/DC desk top adapter, with wide voltage 100V--240VAC input, .single DC output, packaged into a fully enclosed plastic case with integrated output cable and connector.

Size: 93x40x28mm, as following drawing.

RoHS Compliant

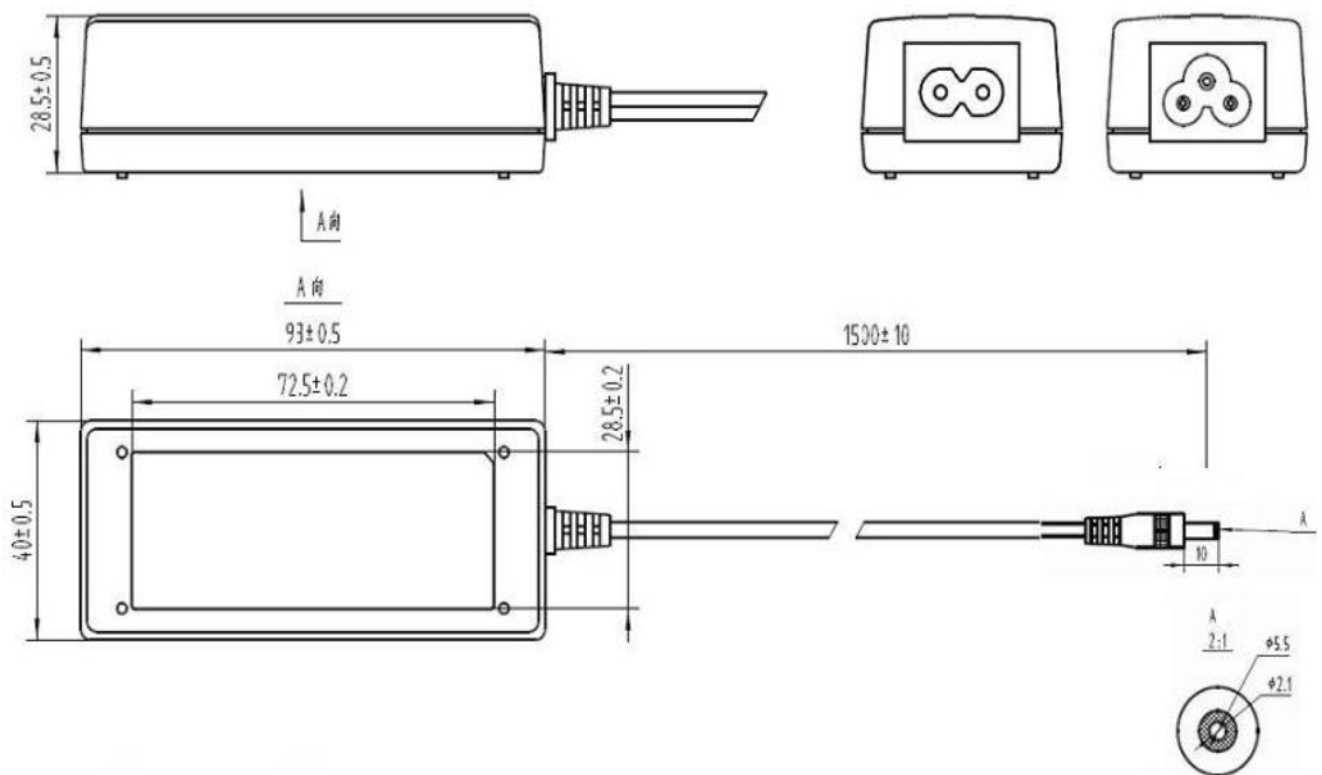

2 Connector

The following specifies the input and output connection requirement of the power supply.

2.1 INPUT CONNECTOR

Two wire, 2P, IEC-C8 connector or three wire, (x), IEC-C13 connector.

2.2 OUTPUT CABLE/CONNECTOR

A two wire cable with standard barrel connector, The length of the output cable is about 1.8M

2.3 PIN ASSIGNMENTS

INPUT(J1)	OUTPUT(CSI)
Pin 1:Line	Outside: GND
Pin 2:Neutral	Inside: Vout(I)

3 Electrical requirements

(Unless specified otherwise, all specifications are at nominal input voltage, full load, 25deg C, PSU at warmed up condition.)

3.1 INPUT

The operating conditions with respect to the AC input voltage are described in this section.

3.1.1 INPUT VOLTAGE

The operating voltage range is: 100V to 240 VAC.

3.1.2 INPUT CURRENT

0.4-0.7A

3.1.3 INPUT FREQUENCY

Input frequency range shall be 47-63Hz.

3.1.4 INRUSH CURRENT

Maximum inrush shall be less than 30A at 240VAC.

3.1.5 EFFICIENCY

The efficiency of the power supply is 83% nominal, Measured at Full Load and nominal AC Input voltage of 100VAC. 250C with the PSU warmed up, at 12V output. O/P Cable drop of 0.30V typical is removed for this calculation. at 24V output. O/P Cable drop of 0.15V typical is removed for this calculation.

3.1.6 POWER FACTOR

Input AC voltage connects to internal diode bridge rectifier and Filter, 30-40W output load is >0.55

3.2 OUTPUT POWER

The operating conditions for the regulated DC output are described in this section.

3.2.1 OUTPUT POWER

Possible Max. Output power is 40-50W.

3.2.2 OUTPUT VOLTAGE

Initial point voltage is measured at Min. Load/ Half Load/Max. load, at nominal input AC voltage, The nominal output voltage of a specific model ARPV-16-12036 is "YY" volt. This voltage change is indicative of change due to process variation and change due to load variation. The set point tolerance is measured with reference to the respective nominal Voltage and expressed as percentage of the nominal output voltage.

Model	Output	Nominal voltage	Setpoint tolerance	User adjust
ARPV-16-12036	+V out(I)	+12V	<4%	NA

3.2.3 OUTPUT CURRENT

Model	Output	Min.Load current	RATED.Load Current	Peak Current limit min(P-P)
ARPV-25-12018	+Vout(I)=12V	0A	3.0A	4.0A

3.2.4 LINE REGULATION

Regulation is measured by varying the line voltage from 100-240VAC, at full load.

Model	OUTPUT	TOLERANCE
ALL	+Vout(I)	<4%

3.2.5 LOAD REGULATION

Measured by varying the load current from MIN Load to FULL load at nominal AC input voltage. Measured at o/p power cord end. This measures output voltage variation of a unit due to load change and is indicative of design capability. The tolerance is measured with reference to the respective nominal Voltage and expressed as percentage of nominal output voltage.

Model	OUTPUT	TOLERANCE
ALL	+Vout(I)	<3%

3.2.6 CROSS REGULATION

Measured at 50% load on output while any other output load changed by 50%.

3.2.7 OUTPUT RIPPLE AND NOISE VOLTAGE (PAPD)

Measured at full load, 100MHz bandwidth, with a 0.1uF Ceramic Cap and a 47uF Tant. Cap/E-Cap. connected at the measurement point. The maximum PARD PK-PK ripple and noise is indicated below.

Model	Output	Max pk-pk
ARPV-16-12036	+Vout(I)=12V	<200mV

3.2.8 OUTPUT TRANSIENT RESPONSE

The load current of measured output is changed between 10% to 100% max load for all models, at 0.1A/sec slew rate, at 100/120Hz, 50% duty cycle. The recovery time and excursion is measured when the output voltage has recovered to within 1% of the load regulation band. Expressed as percentage of the nominal voltage.

Model	Output	RECOVERYTIME To regulation	MAX. EXCURSION From Regulation
ALL	+Vout(I)	<1ms	<3%

3.2.9 OUTPUT TRANSIENT RESPONSE

Long-term output voltage drift over 1000 hours of operation, at Vout (I) is typically less than 0.5%.

3.2.10 OUTPUT OVERSHOOT

The overshoot voltage as a percentage of nominal output voltage at initial power up of the PSU, at 90w full load condition is indicated below. Measured with ref. to the o/p regulation band.

Model	OUTPUT	OVERSHOOT
ALL	+Vout(I)	<5%

3.2.11 OUTPUT PROTECTION

The power supply load shall be protected against a fault condition described below.

3.2.11.1 OVERVOLTAGE

Redundant Feedback type. The load is protected against any output over voltage under any fault condition, the trip voltage depends on the nominal output voltage of the models. It is between 130-150% of rated voltage .

3.2.11.2 OUTPUT SHORT CIRCUIT /OVERLOAD PROTECTION

The PSU shall be protected against overload as per section 3.2.3. The power supply will be protected against output short circuit. Short circuit current shall be less than 0A rms. Under all conditions. Output voltage of less than 50%Vout(I) constitutes a short. The PSU will self recover within a max. of 3 sec. after removal of the fault.

3.2.12 OUTPUT RISE TIME

The time taken by the output to rise from 10% to 90% of the final steady state value, should be as below.

Model	OUTPUT	MAX RISE TIME
ALL	+Vout(I)	<10ms

3.2.13 TURN-ON DELAY

The run-on delay time, from the time AC power is applied to the PSU till the o/p voltage is within the regulation band. Shall be less than 2seconds at 100 VAC. cold start.

3.2.14 OUTPUT HOLD-UP-TIME

The power supply shall maintain the output within it's voltage/current specifications for more than 20ms. after any loss of AC input voltage. Measured at nominal input voltage of 100-240VAC and at point when output is crossing regulation band.

3.2.15 REMOTE SENSE N/A

3.2.16 POWER FALL/POWER GOOD SIGNAL N/A

3.2.17 TEMPERATURE COEFFICIENT

Temperature coefficient over the entire operating temperature range of 0°C to 40°C after one hour warm-up will be as follows:

Model	OUTPUT	TEMP.COEFF.
ALL	+Vout(I)	<2.4mV/°C

4 Environmental Requirements

4.1 TEMPERATURE

Operating temperature range is 0°C to 40°C at the respective rated output power, with free air convection. Surface temperature shall be less than 60°C at 20°C operating temperature. Non-operating temperature range: -40°C to 85°C.

4.2 ALTITUDE

Maximum operating altitude: 10,000 feet, Maximum Non-operating altitude: 40,000 feet.

4.3 HUMIDITY

Non-condensing relative humidity range: 5% to 95%.

4.4.1 VIBRATION

The power supply shall meet operating, non operating and package vibration

vibration	frequency	acceleration	tow time	cycles
Operating	5-500Hz	0.5G	15min,XYZ all 15 min	2
Non operating	5-500Hz	1G	15min,XYZ all 15 min	2
package	5-500Hz	1.5G	15min,XYZ all 30 min	2

4.4.2 SHOCK

The power supply shall meet operating and non operating shock, On floorboards thick for 10mm wood block.

Shock	height	direction	cycles
Operating	0.3m	XYZ all 3 times	6
Non operating	1.0m	XYZ all 3 times	6

4.5 INPUT TRANSIENT SUSCEPTIBILITY

The unit shall comply with requirements of IEC, 1000-4-2, IEC 1000-4-4 and IEC 1000-4-5, will withstand ESD of 8K Contact Discharge, will withstand ESD of 20K Air Discharge, 10 strides, both +ve and -ve, as per IEC 1000-4-2.

4.6 AC-LINE INPUT INRUSH NOISE

Minimum dielectric AC-line inrush voltage noise: Between AC input L to N:

Inrush noise	Tr/ Td	Voltage	Phase	time	cycles
Operating	1.2 μ s /50 μ s	2.0kV	0°	1 min	10
			90°		10
			270°		10
			360°		10

4.7 THERMAL SHUTDOWN NC

5 Safety Requirements

5.1 DIELECTRIC WITHSTAND VOLTAGE

Minimum dielectric withstand voltage: Between input to output: 3000VAC rms/1 minute. Leakage current shall be 5mA maximum.

5.2 LEAKAGE CURRENT

Maximum leakage current from primary to secondary shall be 0.25mA , Minimum voltage 240VAC rms.

5.3 INSULATION RESISTANCE

Minimum insulation resistor from primary to secondary shall be 100M Ω , The voltage DC 500V.

5.4 SAFETY SPACINGS

6.4mm minimum between primary and secondary.

5.5 SAFETY STANDARDS APPROVAL

The power supply will meet Class II, SELV of the following safety agency requirements.

5.51 MARKING

With the following marking: CE

5.6 REI. IABILITY

MTBF@ 25°C shall be 50,000 hours min.

6 Emi Requiremnts

EMI STANDARD: EN55024,EN55022 CLASS B,EN6100-3-2,3.,FCC Class B.