

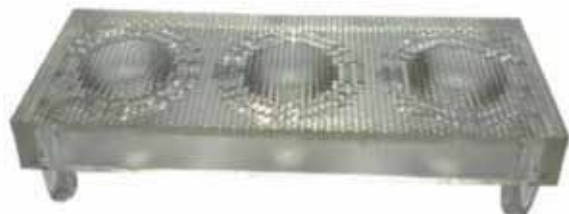

ANGLE	CODE
50 °	3LB50D



LED Type



BOX QUANTITY	210 P C S
BOX SIZE	26 * 26 * 16 cm
BOX WEIGHT	3, 100 Kg

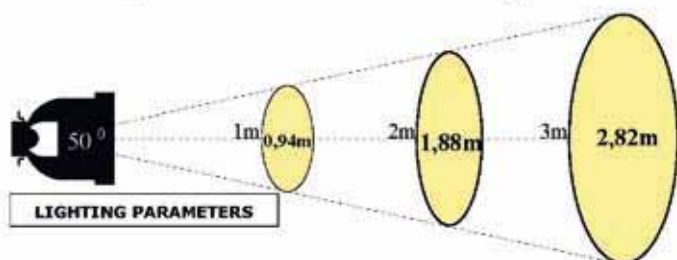
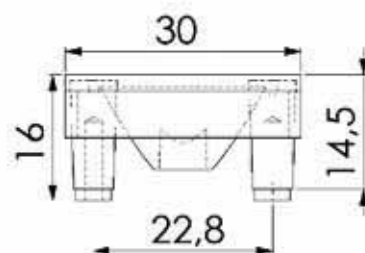
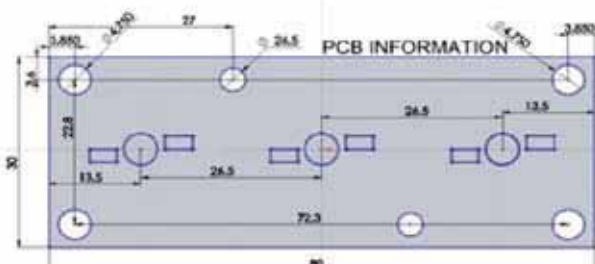
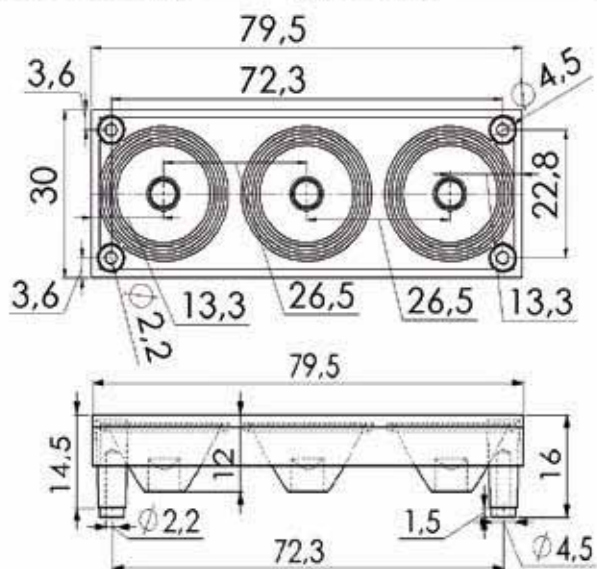

**TURLENS USE :** Street Lighting , Office Lighting , Home Lighting , Stage Lighting , Architectural Lighting , Down Light Lighting , Decorative Lighting

### Lens INFO

Lens Material : Optical Grade Best Available Optical Efficiency

Lens Material : with high UV & Temperature Resistance -40°C ~ +100°C

Lens Material : Light Transmittance High Productivity with 2mm Thickness

**WARNING :** If you Decide to use Glue only, Please Take Special Care of Correct Positioning

