

HP (CD294)

High ripple current ,Smaller size ,Load life of 2000 hours at 105°C,Used in PCB Mounting.

Adapted to the ROHS directive (2002/95/EC).



Specifications

Item	Performance Characteristics							
Operating temperature range	-40°C ~ +105°C			-25°C ~ +105°C				
Rated voltage range	16 ~ 160 V			160 ~ 450 V				
Capacitance tolerance	±20% (120Hz, +20°C)							
Leakage current	I ≤ 0.01CV (μA) 1.5mA (5) (at 20°C, after 5 minutes ,Whichever is smaller)							
Dissipation factor (tg δ) (+20°C, 120Hz)	Rated voltage(V)	16	25	35	50	63~100	160~400	450
	tg δ	0.50	0.40	0.35	0.30	0.20	0.15	0.20
Temperature characteristics (Impedance ratio at 120Hz)	U _R (V)	16~100		160~200		250~450		
	Z-25°C/+20°C	4		4		4		
	Z-40°C/+20°C	15						
Load life	After applying rated voltage with specified ripple current for 2000 hours at +105°C and then resumed 16 hours: Capacitance change : ±20% Initial measured value Leakage current : ≤ Initial specified value Dissipation factor : ≤ 2 times Initial specified value							
Shelf life	After storage for 1000 hours at +105°C, U _R to be applied for 30 minutes and then resumed 16 hours Capacitance change : ±20% Initial measured value Leakage current : ≤ Initial specified value Dissipation factor : ≤ 2 times Initial specified value							

Case size table

Unit: mm

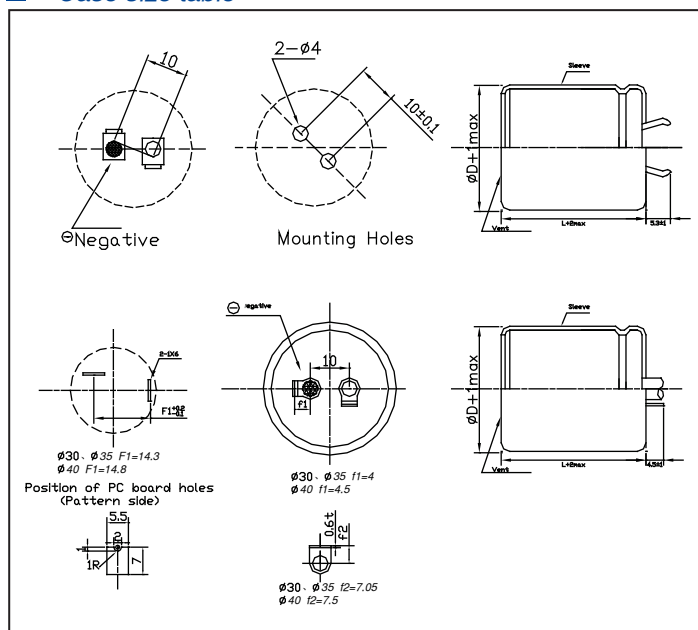

Frequency coefficient

U(V) \ (Hz)	50	100(120)	1K	10K	20K	100K
≤100	0.88	1.00	1.10	1.15	1.15	1.2
160~250	0.81	1.00	1.11	1.18	1.2	1.4
≥315	0.707	1.00	1.14	1.14	1.2	1.65

Temperature coefficient

Temperature(°C)	+40	+55	+70	+85	+105
Factor	2.7	2.5	2.1	1.7	1.0

■ **Dimensions**

ØD × L(mm)

W _V (V) Φ D × L (mm)	16		25		35		50		63		80		100	
	Cap	Ripple	Cap	Ripple	Cap	Ripple	Cap	Ripple	Cap	Ripple	Cap	Ripple	Cap	Ripple
	μF	Arms	μF	Arms	μF	Arms	μF	Arms	μF	Arms	μF	Arms	μF	Arms
22x25	6800	1.6	4700	1.55	3300	1.43	1800	1.31	1200	1.25	820	1.11	560	1.07
22x30	10000	1.99	6800	1.91	3900	1.65	2700	1.70	1800	1.52	1200	1.39	820	0.35
22x35	12000	2.28	8200	2.14	5600	2.02	3300	1.98	2200	1.73	1500	1.61	1000	1.54
22x40	15000	2.64	10000	2.40	6800	2.28	3900	2.25	2700	1.97	1800	1.83	1200	1.74
22x45	18000	2.98	12000	2.69			4700	2.56			2200	2.09	1500	1.99
22x50					8200	2.67	5600	2.89	3300	2.32				
25x25	10000	1.99	6800	1.91	4700	1.78	2700	1.7	1800	1.52	1200	1.39	820	1.35
25x30	12000	2.3	8200	2.16	5600	2.04	3300	2.00	2200	1.75	1500	1.62	1000	1.56
25x35	15000	2.68	10000	2.44	6800	2.31	3900	2.28	2700	1.99	2200	2.01	1200	1.76
25x40	18000	3.04	12000	2.74	8200	2.60	5600	2.81	3300	2.27			1500	2.03
25x45	22000	3.4	15000	3.15	10000	2.92			3900	2.54	2700	2.43	1800	2.28
25x50	27000	3.81	18000	3.54	12000	3.26	6800	3.37	4700	2.88	3300	2.76	2200	2.57
30x25	12000	2.38	8200	2.25	5600	2.12	3900	2.22	2700	1.93	1800	1.81	1200	1.71
30x30	18000	3.00	12000	2.70	8200	2.56	4700	2.58	3300	2.24	2200	2.10	1500	2.00
30x35	22000	3.39	15000	3.13	10000	2.92	5600	2.95	3900	2.55	2700	2.43	1800	2.27
30x40	27000	3.83	18000	3.54	12000	3.28	6800	3.39	4700	2.9	3300	2.78	2200	2.59
30x45	33000	4.3	22000	4.24	15000	3.74	8200	3.71	5600	3.28	3900	3.12	2700	2.94
30x50	39000	4.74					10000	4.09	6800	3.73	4700	3.56	3300	3.32
35x25	18000	3.10	12000	2.80	8200	2.78	4700	2.67	3300	2.41	2200	2.17	1500	2.07
35x30	27000	3.74	15000	3.22	12000	3.20	6800	3.31	4700	2.83	3300	2.71	2200	2.52
35x35	33000	4.24	22000	3.96	15000	3.69	8200	3.66	5600	3.24	3900	3.07	2700	2.90
35x40	39000	4.72			18000	4.16	10000	4.07	6800	3.71	4700	3.50	3300	3.31
35x45	47000	5.27	27000	4.75			12000	4.50	8200	4.16	5600	3.87	3900	3.69
35x50			33000	5.39	22000	4.92			10000	4.69	6800	4.19	4700	4.14

W _V (V) Φ D × L (mm)	160		200		220		250		400		420		450	
	Cap	Ripple	Cap	Ripple	Cap	Ripple	Cap	Ripple	Cap	Ripple	Cap	Ripple	Cap	Ripple
	μF	Arms	μF	Arms	μF	Arms	μF	Arms	μF	Arms	μF	Arms	μF	Arms
22x25	330	1.16	220	1.08	220	1.00	180	0.94	68	0.47	68	0.55		
22x30	390	1.43	330	1.30	270	1.15	220	1.10	82	0.56	100	0.70	39	0.35
22x35	470	1.52	390	1.41	330	1.25	270	1.13	120	0.64	120	0.75	47	0.41
22x40	560	1.62	470	1.50	390	1.40	330	1.20	150	0.70	150	0.83		
22x45	680	1.70	560	1.58	470	1.61	390	1.26			180	0.90	56	0.47
22x50	820	1.81	680	1.68	560	1.80	470	1.37	180	0.78			68	0.54
25x25	470	1.55	330	1.35			220	1.15	82	0.65				
25x30	560	1.73	470	1.47			330	1.30	120	0.70				
25x35	680	1.81	560	1.65			390	1.41	150	0.73				
25x40	820	1.98	680	1.80			470	1.52	180	0.82	220	1.07	82	0.62
25x45	1000	2.04					560	1.59	220	0.87			100	0.67
25x50	1200	2.12	820	1.87			680	1.66	270	0.94			120	0.77
30x25	680	1.82	470	1.56			330	1.30	120	0.78				
30x30	820	1.98	680	1.82			470	1.36	180	0.83				
30x35	1000	2.14	820	1.99			560	1.57	220	0.86	270	1.18		
30x40	1200	2.22			820	2.19	680	1.76	270	0.95	330	1.42	150	0.85
30x45	1500	2.46	1000	2.17	1000	2.50	820	1.83	330	1.11				
30x50			1200	2.22			1000	1.87	390	1.15	390	1.67	180	1.01
35x25	820	1.93	680	1.96			470	1.40	180	0.86				
35x30	1200	2.40	820	2.07			560	1.56	270	0.91			120	0.72
35x35	1500	2.53	1000	2.22			820	1.82	330	1.13				
35x40			1200	2.42	1200	2.79	1000	1.99	390	1.26				
35x45	1800	2.98	1500	2.59			1200	2.10	470	1.31	470	2.07	220	1.12
35x50	2200	3.10	1800	2.70					560	1.50			270	1.29

└──────────┘ Rated ripple current(A,+105°C,120Hz)

High-Power