

FYL-5019RGBC1C-CA

Features:

- High intensity
- General purpose leads
- RoHs compliant.

Descriptions:

- Dice material: R: AlGaInP
G: InGaN
B: InGaN
- Emitting Color: Red /Pure Green /blue
- Device Outline: $\Phi 5\text{mm}$ Round Type.
- Lens Type: Water clear.

Radiation pattern.

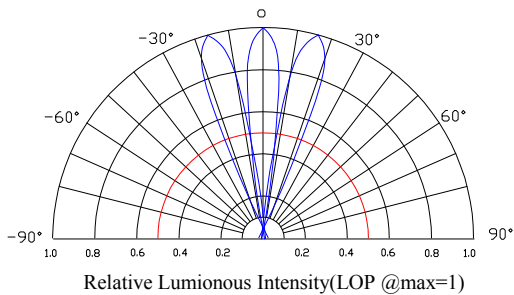

Package configuration

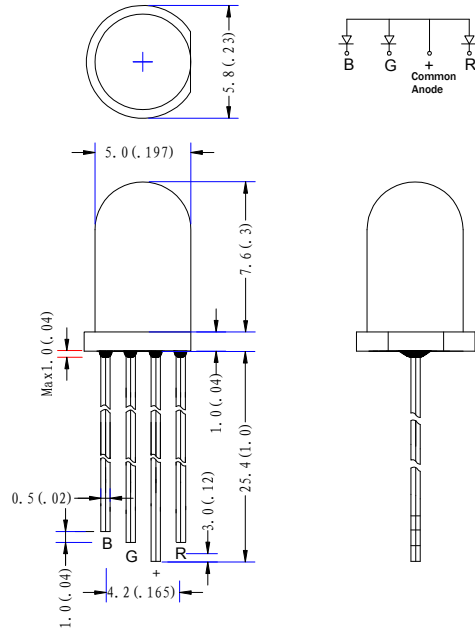

- ◆ All dimensions are millimeters (inches)
- ◆ Tolerance is $\pm 0.25\text{mm}$ (.010") unless otherwise noted.

Absolute maximum ratings($T_a = 25^\circ\text{C}$)

Parameter	MAX.		Unit
Power Dissipation	R	50	mW
	G	80	
	B	80	
Peak Forward Current (1/10 Duty Cycle, 0.1ms Pulse Width)	100		mA
Continuous Forward Current	R	35	mA
	G	20	
	B	20	
Derating Linear From 50°C	0.4		mA/ $^\circ\text{C}$
Reverse Voltage	5		V
Operating Temperature Range	-30 $^\circ\text{C}$ to +80 $^\circ\text{C}$		
Storage Temperature Range	-40 $^\circ\text{C}$ to +100 $^\circ\text{C}$		
Lead Soldering Temperature [4mm (.157") From Body]	260 $^\circ\text{C}$ for 5 Seconds		

Electrical and optical characteristics(Ta=25 °c)

Parameter	Symbol	Min.	Typ.	Max.	Unit	Test Condition
Luminous Intensity	I _v	R	–	220	–	mcd
		G	–	7500	–	
		B	–	1000	–	
Viewing Angle	2θ _{1/2}	R	10	15	20	Deg
		G	10	15	20	
		B	10	15	20	
Peak Emission Wavelength	λ _p	R	640	645	655	nm
		G	515	520	525	
		B	465	470	475	
Dominant Wavelength	λ _d	R	635	640	645	nm
		G	518	523	528	
		B	463	468	473	
Spectral Line Half-Width	Δλ	R	15	20	25	nm
		G	30	35	40	
		B	25	30	35	
Forward Voltage	V _F	R	1.9	2.0	2.4	V
		G	2.8	3.2	3.6	
		B	2.8	3.2	3.6	

 I_F=20mA

Typical Electrical Characteristics Curves (25 °c Ambient Temperature Unless Otherwise Noted)

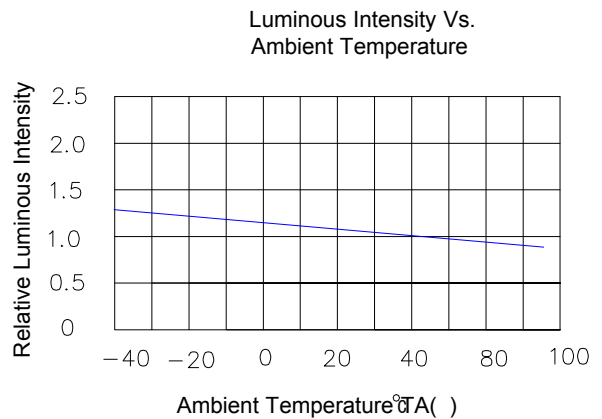
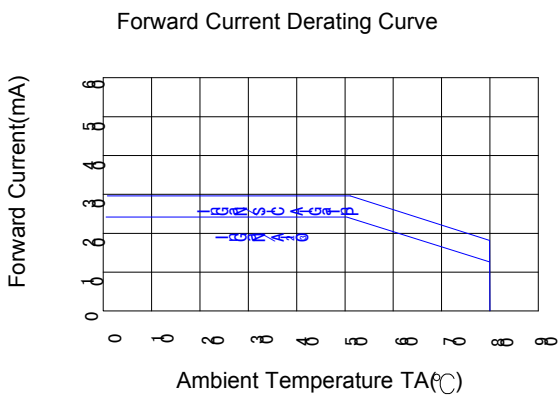
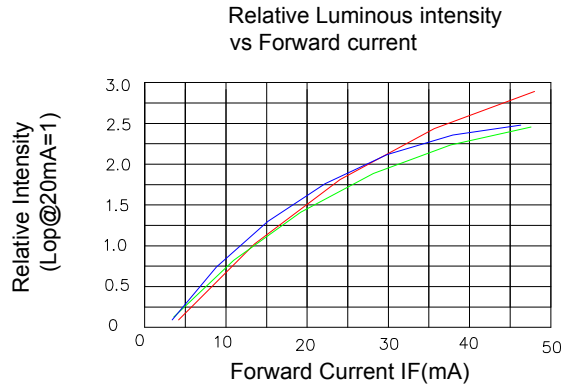
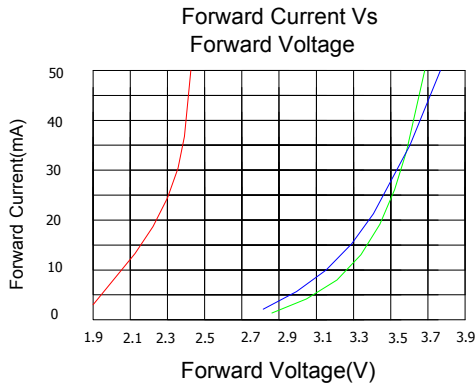
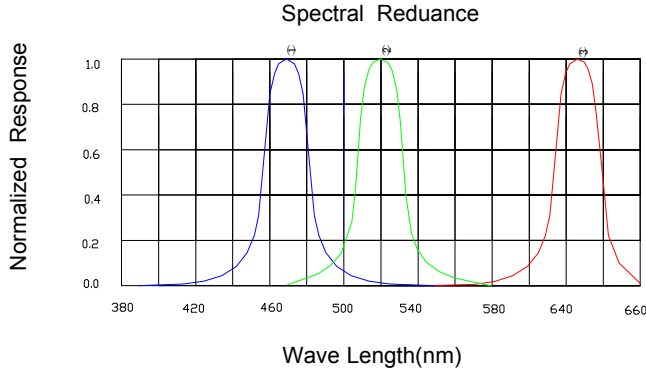

LAMP PACKING.

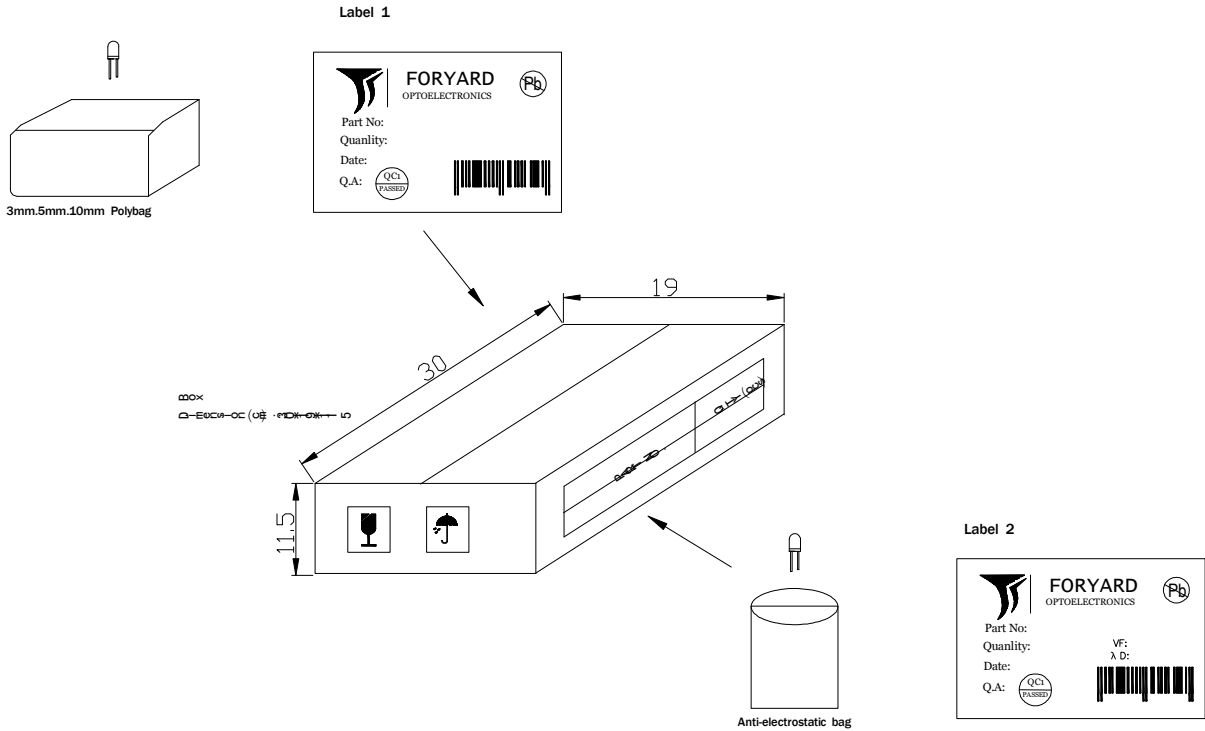

DEVICE	QTY/polybag(pcs)	Polybag/box A	Fig
5mm(T-1 3/4)	1000	8 bags	Label 1
3mm(T-1)	1000	10 bags	Label 1
10mm(T-1)	250	8 bags	Label 1
Blue/Green/White	500pcs	8 bags	Label 2

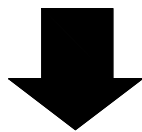

CARTON
Dimension(cm):39*32*38

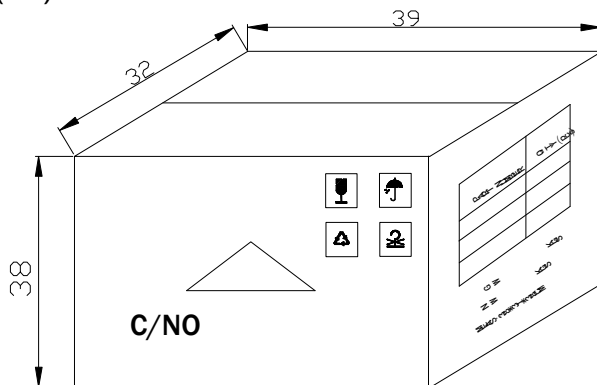

6 Boxes/Carton
 5mm:48,000pcs
 3mm:60,000pcs
 10mm:12,000pcs
 Blue/Pure Green/bluish Green
 /White:24,000pcs