

Features



- Surface mount devices
- Very high voltage surge capabilities
- Available in lead-free version
- Agency Recognition: UL、CSA、TUV



LMV series

Surface mount devices

Product Dimensions

Part number	A Max	B Max	C Max	D Max	E Max	F Max	Figure
LMV170F	19.4	12.3	8.3	2.4	10.4	2.3	1
LMV200F	19.4	12.3	8.3	2.4	10.4	2.3	1
LMV250F	17.6	11.7	11.2	5.2	2.8	1.0	2
LMV400F	17.6	11.7	11.2	5.2	2.8	1.0	2

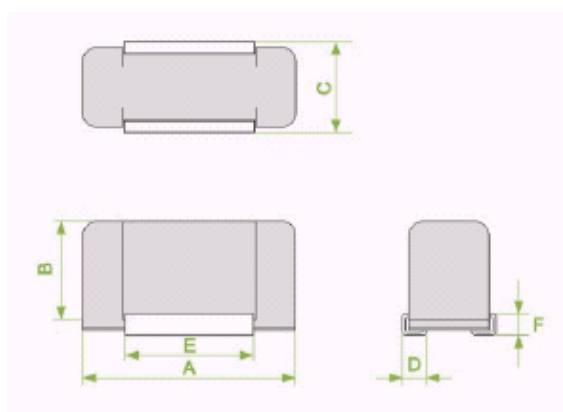

Figure 1

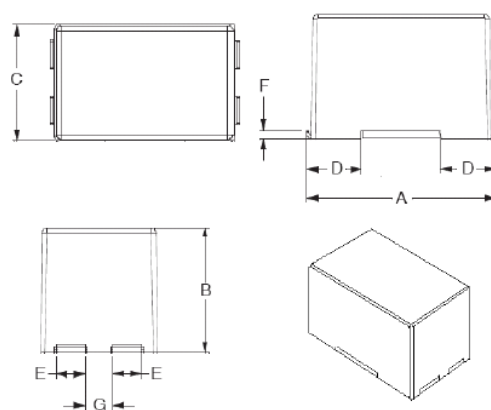
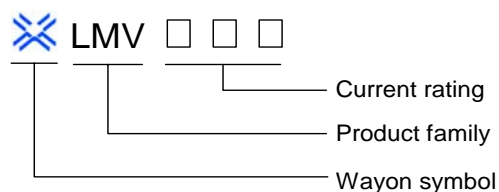

Figure 2

Marking system



* Lead-free devices are available,
the right logo is lead-free mark of wayon.



Electrical Characteristics

Part number	I_H	I_T	T_{trip}		$V_{max\ interrupt}$	I_{max}	Pd_{typ}	R_{min}	R_{max}
	(A)	(A)	Current(A)	Time (S)	(V)	(A)	(W)	(Ω)	(Ω)
LMV170F	0.17	0.34	1.00	10.00	600	3.0	2.50	4.0	9.0
LMV200F	0.20	0.40	1.00	12.00	600	3.0	2.50	4.0	7.5
LMV250F	0.25	0.86	3.00	1.0	600	3.0	2.00	1.0	3.5
LMV400F	0.40	1.00	3.00	4.0	600	3.0	2.00	0.5	1.05

I_H =Hold current: maximum current at which the device will not trip at 25°C still air.

I_T =Trip current: minimum current at which the device will always trip at 25°C still air.

$V_{max\ interrupt}$ =Maximum voltage device can withstand without damage at rated current.

I_{max} =Maximum fault current device can withstand without damage at rated voltage.

T_{trip} =Maximum time to trip(s) at assigned current.

P_{dtyp} =Typical power dissipation: typical amount of power dissipated by the device when in state air environment.

R_{min} =Minimum device resistance at 25°C prior to tripping.

R_{max} =Maximum device resistance at 25°C prior to tripping.

Thermal Derating Chart- $I_H(A)$

Part number	Maximum ambient operating temperatures(°C)								
	-40	-20	0	25	40	50	60	70	85
LMV170F	0.264	0.230	0.200	0.170	0.140	0.125	0.100	0.094	0.070
LMV200F	0.310	0.275	0.238	0.200	0.165	0.147	0.128	0.110	0.083
LMV250F	0.400	0.350	0.300	0.250	0.198	0.170	0.141	0.117	0.083
LMV400F	0.640	0.560	0.480	0.400	0.320	0.270	0.230	0.190	0.130

Test Procedures And Requirements

Test	Test Conditions	Accept/Reject Criteria
Resistance	In still air @ 25°C	$R_{min} \leq R \leq R_{max}$
Time to Trip	Specified current, V_{max} , 25°C	$T \leq$ maximum Time to Trip
Hold Current	30min, at I_H	No trip
Trip Cycle Life	V_{max} , I_{max} , 100cycles	No arcing or burning
Trip Endurance	V_{max} , 24hours	No arcing or burning

Typical Time-to-Trip Charts at 25°C

A=LMV170F/LMV200F

B=LMV250F

C=LMV400F

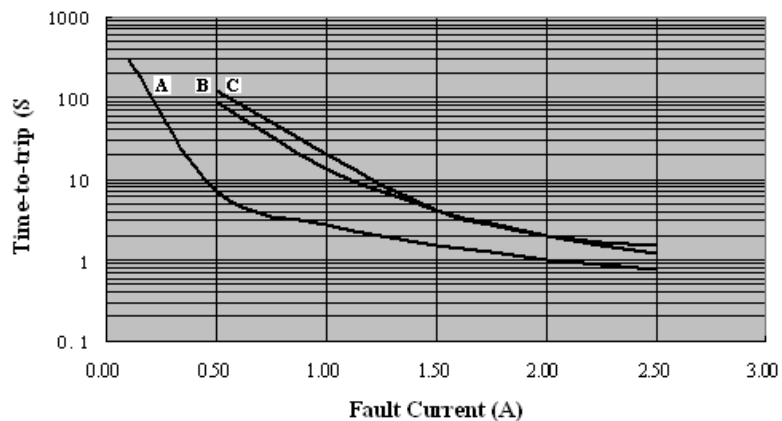

Package Information

Bulk:

LMV170F~LMV400F.....200pcs per bag

Tape & Reel:

LMV170F~LMV400F.....300pcs per reel