

Current Sensing Thick Film Chip Resistor (RS Series)

Scope

– This specification applies to all sizes of rectangular-type fixed chip resistors with Ruthenium-base as material.

Features

- Low inductance
- Highly reliable multilayer electrode construction
- Higher component and equipment reliability
- Reduced size of final equipment reliability



Applications

- Power Management Applications
- Switching Power Supply
- Over Current Protection in Audio Application
- Voltage Regulation Module (VRM)
- DC-DC Converter, Battery Pack, Charger, Adaptor
- Automotive Engine Control
- Disk Driver

Construction

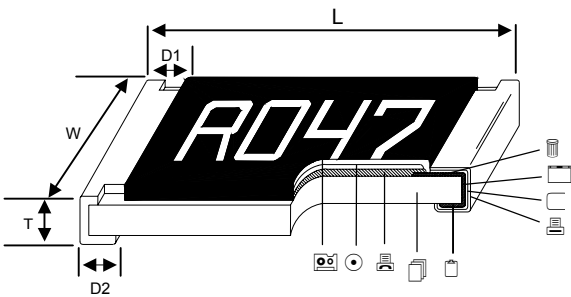

	Alumina Substrate		Edge Electrode (NiCr)		Resistor Layer (RuO ₂ /Ag)
	Bottom Electrode (Ag)		Barrier Layer (Ni)		Primary Overcoat (Glass)
	Top Electrode (Ag-Pd)		External Electrode (Sn)		Secondary Overcoat (Epoxy)

Dimensions

Unit: mm

Type	Size (Inch)	L	W	T	D1	D2	Weight (g) (1000pcs)
RS-02	0402	1.00±0.05	0.50±0.05	0.35±0.05	0.20±0.10	0.20±0.10	0.620
RS-03	0603	1.60±0.10	0.80±0.10	0.45±0.10	0.30±0.20	0.30±0.20	2.042
RS-05	0805	2.00±0.10	1.25±0.10	0.50±0.10	0.35±0.20	0.40±0.20	4.368
RS-06	1206	3.10±0.10	1.55±0.10	0.55±0.10	0.50±0.25	0.50±0.20	8.947
RS-10	1210	3.10±0.10	2.60±0.15	0.55±0.10	0.50±0.25	0.50±0.20	15.959
RS-0A	2010	5.00±0.10	2.50±0.15	0.55±0.10	0.60±0.25	0.50±0.20	24.241
RS-12	2512	6.35±0.10	3.10±0.15	0.55±0.10	0.60±0.25	0.50±0.20	39.448

Part Numbering

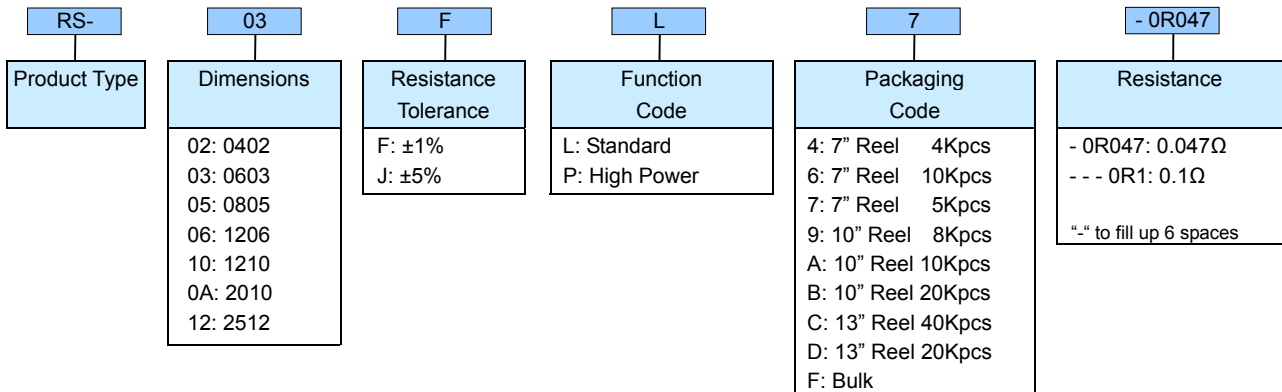

Derating Curve

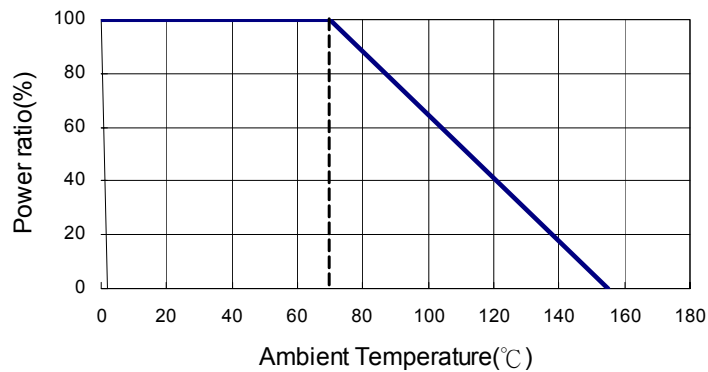

Standard Electrical Specifications

Type	Item	Power Rating at 70°C	Operating Temp. Range	Resistance Range (mΩ)		TCR (PPM/°C)
				±1%	±5%	
RS-02 (0402)		1/16W	-55~+155°C	50 - 99		±800
				100 - 499		±500
				500 - 976		±200
RS-03 (0603)		1/10W	-55~+155°C	20 - 47		±1200
				50 - 99		±800
				100 - 499		±500
				500 - 976		±200
RS-05 (0805)		1/8W	-55~+155°C	10 - 18		±1500
				20 - 47		±1200
RS-06 (1206)		1/4W	-55~+155°C	50 - 99		±800
				100 - 499		±500
				500 - 976		±200
RS-10 (1210)		1/3W	-55~+155°C	10 - 18		±1500
				20 - 47		±800
RS-0A (2010)		3/4W		50 - 99		±800
				100 - 499		±200
RS-12 (2512)		1W		500 - 976		±200

Operating Voltage= $\sqrt{P \cdot R}$

Overload Voltage= $2.5 \cdot \sqrt{P \cdot R}$

High Power Rating Electrical Specifications

Type	Item	Power Rating at 70°C	Operating Temp. Range	Resistance Range (mΩ)		TCR (PPM/°C)
				±1%	±5%	
RS-02 (0402)		1/10W	-55~+155°C	50 - 99	100 - 499	±800
				100 - 499	500 - 976	±500
				500 - 976		±200
RS-03 (0603)		1/8W	-55~+155°C	20 - 47	50 - 99	±1200
				50 - 99	100 - 499	±800
				100 - 499	500 - 976	±500
RS-05 (0805)		1/4W	-55~+155°C	10 - 18	20 - 47	±1500
				20 - 47	50 - 99	±1200
				50 - 99	100 - 499	±800
RS-06 (1206)		1/3W	-55~+155°C	100 - 499	500 - 976	±500
				500 - 976		±200
RS-10 (1210)		1/2W	-55~+155°C	10 - 18	20 - 47	±1500
				20 - 47	50 - 99	±800
				50 - 99	100 - 499	±800
RS-0A (2010)		1W	-55~+155°C	100 - 499	500 - 976	±200
RS-12 (2512)		2W		500 - 976		±200

Operating Voltage= $\sqrt{P \cdot R}$

Overload Voltage= $2.5 \cdot \sqrt{P \cdot R}$

■ Viking is capable of manufacturing the optional spec based on customer's requirement.

Soldering Condition

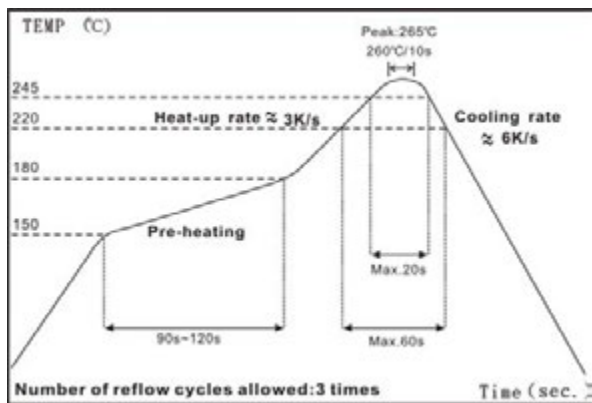

IR Reflow Soldering

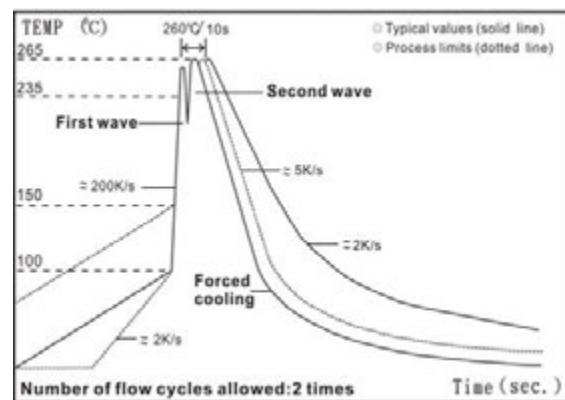

Wave Soldering (Flow Soldering)

- (1) Time of IR reflow soldering at maximum temperature point 260°C : 10s
- (2) Time of wave soldering at maximum temperature point 260°C : 10s
- (3) Time of soldering iron at maximum temperature point 410°C : 5s

■ Environmental Characteristics

Item	Requirement		Test Method
	±1%	±5%	
Temperature Coefficient of Resistance (T.C.R.)	As Spec.		JIS C 5201-1 4.8 IEC 60115-1 4.8 -55°C~+125°C, 25°C is the reference temperature
Short Time Overload	±(1.0%+0.05Ω)	±(2.0%+0.05Ω)	JIS C 5201-1 4.13 IEC 60115-1 4.13 2.5 times RCWV or Max. overload voltage for 5 seconds, 2 seconds for high power series
Insulation Resistance	≥ 10G		JIS C 5201-1 4.6 IEC 60115-1 4.6 Max. overload voltage for 1 minute
Endurance	±(2.0%+0.10Ω)	±(3.0%+0.10Ω)	JIS C 5201-1 4.25 IEC 60115-1 4.25.1 70±2°C, Max. working voltage for 1000 hrs with 1.5 hrs "ON" and 0.5 hrs "OFF"
Damp Heat with Load	±(2.0%+0.10Ω)	±(3.0%+0.10Ω)	JIS C 5201-1 4.24 40±2°C, 90~95% R.H., Max. working voltage for 1000 hrs with 1.5 hrs "ON" and 0.5 hrs "OFF"
Dry Heat	±(1.0%+0.05Ω)	±(1.5%+0.10Ω)	JIS C 5201-1 4.23.2 IEC 60115-1 2.23.2 at +155°C for 1000 hrs
Bending Strength	±(1.0%+0.05Ω)	±(1.0%+0.05Ω)	JIS C 5201-1 4.33 IEC 60115-1 4.33 Bending once for 5 seconds 2010, 2512 sizes: 2mm Other sizes: 3mm
Solderability	>95% coverage		JIS C 5201-1 4.17 IEC 60115-1 4.17 245±5°C for 3 seconds
Resistance to Soldering Heat	±(0.5%+0.05Ω)	±(1.0%+0.05Ω)	JIS C 5201-1 4.18 IEC 60115-1 4.18 260±5°C for 10 seconds
Voltage Proof	No breakdown or flashover		JIS C 5201-1 4.7 IEC 60115-1 4.7 1.42 times RCWV (RMS) for 1 minute
Leaching	Individual leaching area ≤ 5% Total leaching area ≤ 10%		JIS C 5201-1 4.18 IEC 60068-2-58 8.2.1 260±5°C for 30 seconds
Rapid Change of Temperature	±(0.5%+0.05Ω)	±(1.0%+0.05Ω)	JIS C 5201-1 4.19 IEC 60115-1 4.19 -55°C to +155°C, 5 cycles

■ Storage Temperature: 25±3°C; Humidity < 80%RH

■ Packaging

Reel Specifications & Packaging Quantity

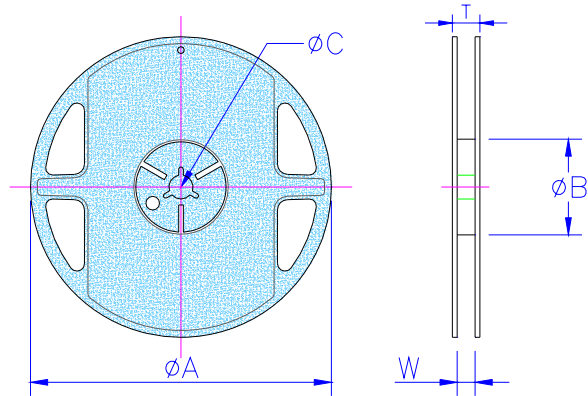

Unit: mm

Type	Packaging Quantity		Tape Width	Reel Diameter	ϕA	ϕB	ϕC	W	T
RS-02	Paper	10K	8mm	7 inch	178.5±1.5	60 ^{+1/-0}	13.0±0.2	9.0±0.5	12.5±0.5
		20K		10 inch	254±1	100±0.5	13.0±0.2	9.5±0.5	13.5±0.5
		40K		13 inch	330±1	100±0.5	13.0±0.2	9.5±0.5	13.5±0.5
RS-03	Paper	5K	8mm	7 inch	178.5±1.5	60 ^{+1/-0}	13.0±0.2	9.0±0.5	12.5±0.5
RS-05		10K		10 inch	254±1	100±0.5	13.0±0.2	9.5±0.5	13.5±0.5
RS-06		20K		13 inch	330±1	100±0.5	13.0±0.2	9.5±0.5	13.5±0.5
RS-10		20K		13 inch	330±1	100±0.5	13.0±0.2	9.5±0.5	13.5±0.5
RS-0A	Embossed	4K	12mm	7 inch	178.5±1.5	60 ^{+1/-0}	13.0±0.5	13.0±0.5	15.5±0.5
RS-12		8K		10 inch	250±1	62±0.5	13.0±0.5	12.5±0.5	16.5±0.5

Paper Tape Specifications

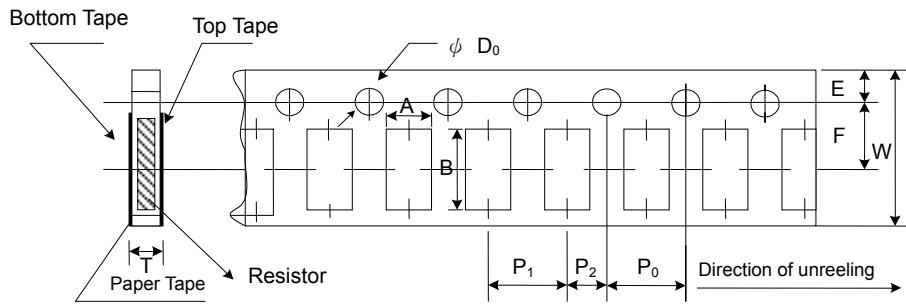

Unit: mm

Type	A	B	W	E	F	P_0	P_1	P_2	ϕD_0	T
RS-02	0.65±0.10	1.15±0.1	8.0±0.2	1.75±0.1	3.50±0.05	4.00±0.10	2.00±0.05	2.00±0.05	1.50+0.1,-0	0.45±0.1
RS-03	1.10±0.10	1.90±0.1	8.0±0.2	1.75±0.1	3.50±0.05	4.00±0.10	4.00±0.05	2.00±0.05	1.50+0.1,-0	0.70±0.1
RS-05	1.60±0.10	2.40±0.2	8.0±0.2	1.75±0.1	3.50±0.05	4.00±0.10	4.00±0.05	2.00±0.05	1.50+0.1,-0	0.85±0.1
RS-06	1.90±0.10	3.50±0.2	8.0±0.2	1.75±0.1	3.50±0.05	4.00±0.10	4.00±0.05	2.00±0.05	1.50+0.1,-0	0.85±0.1
RS-10	2.90±0.10	3.50±0.2	8.0±0.2	1.75±0.1	3.50±0.05	4.00±0.10	4.00±0.05	2.00±0.05	1.50+0.1,-0	0.85±0.1

Embossed Plastic Tape Specifications

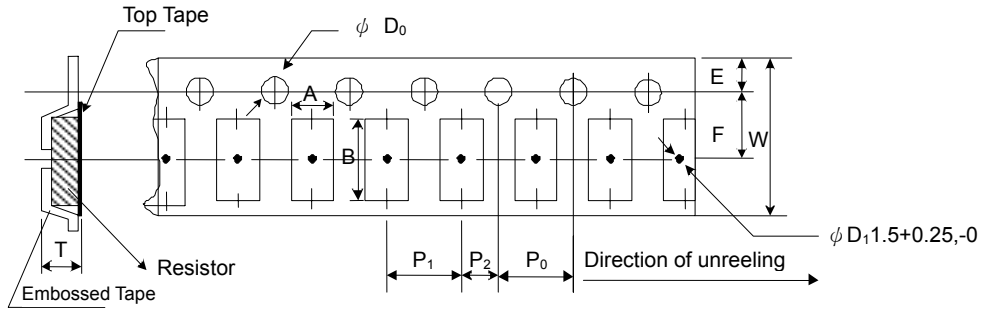

Unit: mm

Type	A	B	W	E	F	P ₀	P ₁	P ₂	ϕD_0	T
RS-0A	2.8±0.10	5.5±0.10	12.0±0.3	1.75±0.1	5.5±0.05	4.00±0.10	4.00±0.1	2.00±0.05	1.50+0.1, -0	1.2 ⁺⁰
RS-12	3.5±0.10	6.7±0.10	12.0±0.3	1.75±0.1	5.5±0.05	4.00±0.10	4.00±0.1	2.00±0.05	1.50+0.1, -0	1.2 ⁺⁰

Marking

No marking for 0402

1%, 5% for 0805/1206/1210/2010/2512: 4 digits marking

Example:

Resistance	47mΩ	75mΩ	15mΩ	750mΩ	820 mΩ
Marking	R047	R075	R015	R750	R820

1%, 5% for 0603: 3 digits marking in E24

1% for 0603: 3 digits marking with under-line in E96 (non-including E24 series)



3 digits marking for E24 or R value suffix is zero in E96: R10=100mΩ R28=280mΩ

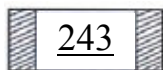

3 digits marking for E96: 243=243mΩ 511=511mΩ

E24 code	10	11	12	13	15	16	18	20	22	24	27	30	33	36	39	43	47	51	56	62	68	75	82	91
----------	----	----	----	----	----	----	----	----	----	----	----	----	----	----	----	----	----	----	----	----	----	----	----	----

Recommend Land Pattern

Unit: mm

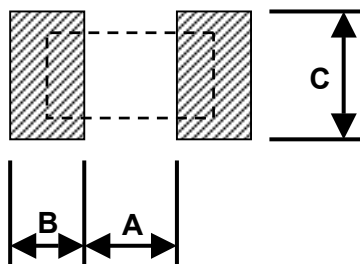

Type	A	B	C
RS-02	0.50	0.45	0.60
RS-03	0.90	0.60	0.90
RS-05	1.20	0.70	1.30
RS-06	2.00	0.90	1.60
RS-10	2.00	0.90	2.80
RS-0A	3.80	0.90	2.80
RS-12	3.80	1.60	3.50