

# MQ136 Semiconductor Sensor for Sulfur Dioxide

Sensitive material of MQ136 gas sensor is SnO<sub>2</sub>, which with lower conductivity in clean air. When the target SO<sub>2</sub> gas exist, the sensor's conductivity is more higher along with the gas concentration rising. Please use simple electrocircuit, Convert change of conductivity to correspond output signal of gas concentration.

MQ136 gas sensor has high sensitivity to SO<sub>2</sub>, also could be used to detect other vapor which contains Sulfur. It has low sensitivity to normal combustible gases, which is with low cost and suitable for different application.

### Character

- \* Good sensitivity to SO<sub>2</sub>
- \* Long life and low cost
- \* Simple drive circuit

### Application

- \* Domestic SO<sub>2</sub> concentration detector
- \* Industrial SO<sub>2</sub> leakage detector
- \* Portable SO<sub>2</sub> detector

### Configuration

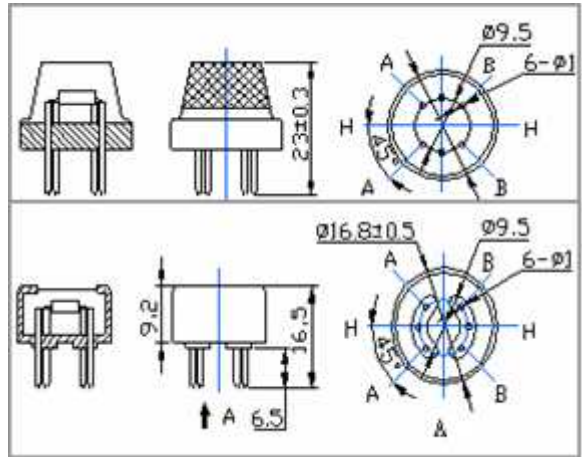

### Technical Data

#### Basic test loop

Model No.		MQ136	
Sensor Type		Semiconductor	
Standard Encapsulation		Bakelite (Black Bakelite)	
Detection Gas		SO <sub>2</sub>	
Concentration		1-200ppm (SO <sub>2</sub> )	
Circuit	Loop Voltage	V <sub>c</sub>	≤24V DC
	Heater Voltage	V <sub>H</sub>	5.0V±0.2V AC or DC
	Load Resistance	R <sub>L</sub>	Adjustable
Character	Heater Resistance	R <sub>H</sub>	31Ω±3Ω (Room Tem.)
	Heater consumption	P <sub>H</sub>	≤900mW
	Sensing Resistance	R <sub>s</sub>	2KΩ-20KΩ (in 50ppm SO <sub>2</sub> )
	Sensitivity	S	$R_s(\text{in air}) / R_s(50\text{ppm SO}_2) \geq 3$
	Slope	α	$\leq 0.6 (R_{100\text{ppm}} / R_{50\text{ppm SO}_2})$
Condition	Tem. Humidity	20°C±2°C; 65%±5%RH	
	Standard test circuit	V <sub>c</sub> : 5.0V±0.1V; V <sub>H</sub> : 5.0V±0.1V	
	Preheat time	Over 48 hours	

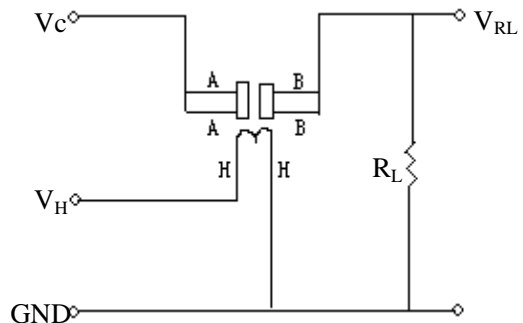

The above is basic test circuit of the sensor. The sensor need to be put 2 voltage, heater voltage (V<sub>H</sub>) and test voltage (V<sub>C</sub>). V<sub>H</sub> used to supply certified working temperature to the sensor, while V<sub>C</sub> used to detect voltage (V<sub>RL</sub>) on load resistance (R<sub>L</sub>) whom is in series with sensor. The sensor has light polarity, V<sub>c</sub> need DC power. V<sub>C</sub> and V<sub>H</sub> could use same power circuit with precondition to assure performance of sensor. In order to make the sensor with better performance, suitable R<sub>L</sub> value is needed:

Power of Sensitivity body (P<sub>s</sub>):  $P_s = V_c^2 \times R_s / (R_s + R_L)^2$

Resistance of sensor( $R_s$ ):  $R_s=(V_c/V_{RL}-1)\times R_L$

**Sensitivity Characteristics**

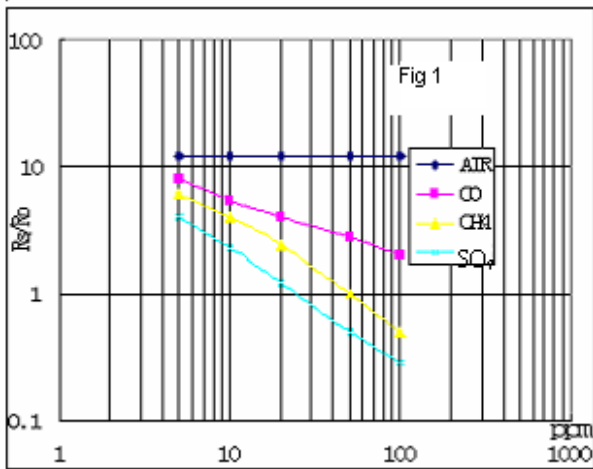

Fig.1 shows the typical sensitivity characteristics of the MQ136, ordinate means resistance ratio of the sensor ( $R_s/R_o$ ), abscissa is concentration of gases.  $R_s$  means resistance in different gases,  $R_o$  means resistance of sensor in 50ppm  $SO_2$ . All test are under standard test conditions.

**Influence of Temperature/Humidity**

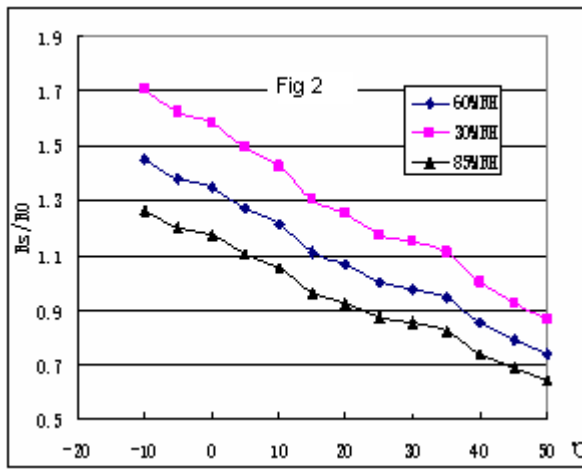
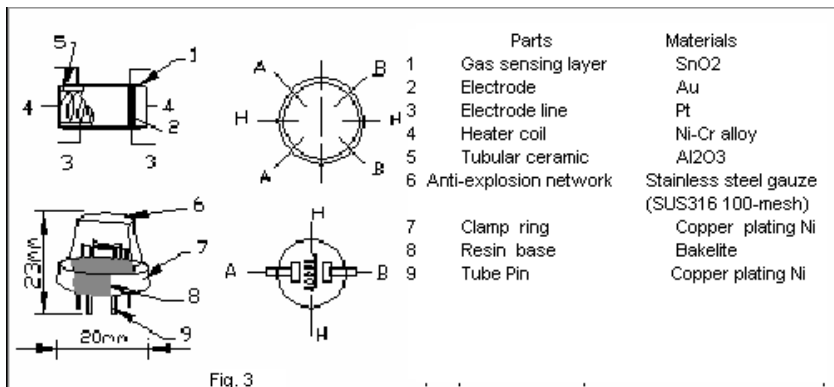

Fig.2 shows the typical temperature and humidity characteristics. Ordinate means resistance ratio of the sensor ( $R_s/R_o$ ),  $R_s$  means resistance of sensor in 50ppm  $SO_2$  under different tem. and humidity.  $R_o$  means resistance of the sensor in environment of 50ppm  $SO_2$ , 20°C/65%RH

**Structure and configuration**



Structure and configuration of MQ136 gas sensor is shown as Fig. 3, sensor composed by micro  $AL_2O_3$  ceramic tube, Tin Dioxide ( $SnO_2$ ) sensitive layer, measuring electrode and heater are fixed into a crust made by plastic and stainless steel net. The heater provides necessary work conditions for work of sensitive components. The enveloped MQ-4 have 6 pin, 4 of them are used to fetch signals, and other 2 are used for providing heating current.

## **Notification**

### **1 Following conditions must be prohibited**

#### 1.1 Exposed to organic silicon steam

Organic silicon steam cause sensors invalid, sensors must be avoid exposing to silicon bond, fixture, silicon latex, putty or plastic contain silicon environment

#### 1.2 High Corrosive gas

If the sensors exposed to high concentration corrosive gas (such as  $H_2S$ ,  $SO_x$ ,  $Cl_2$ ,  $HCl$  etc), it will not only result in corrosion of sensors structure, also it cause sincere sensitivity attenuation.

#### 1.3 Alkali, Alkali metals salt, halogen pollution

The sensors performance will be changed badly if sensors be sprayed polluted by alkali metals salt especially brine, or be exposed to halogen such as fluorin.

#### 1.4 Touch water

Sensitivity of the sensors will be reduced when splattered or dipped in water.

#### 1.5 Freezing

Do avoid icing on sensor's surface, otherwise sensor would lose sensitivity.

#### 1.6 Applied voltage higher

Applied voltage on sensor should not be higher than stipulated value, otherwise it cause down-line or heater damaged, and bring on sensors' sensitivity characteristic changed badly.

#### 1.7 Voltage on wrong pins

For 6 pins sensor, if apply voltage on 1、3 pins or 4、6 pins, it will make lead broken, and without signal when apply on 2、4 pins

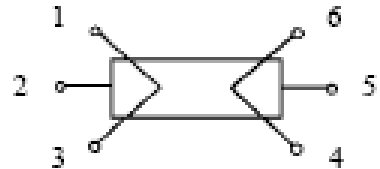

### **2 Following conditions must be avoided**

#### 2.1 Water Condensation

Indoor conditions, slight water condensation will effect sensors performance lightly. However, if water condensation on sensors surface and keep a certain period, sensor' sensitivity will be decreased.

#### 2.2 Used in high gas concentration

No matter the sensor is electrified or not, if long time placed in high gas concentration, if will affect sensors characteristic.

#### 2.3 Long time storage

The sensors resistance produce reversible drift if it's stored for long time without electrify, this drift is related with storage conditions. Sensors should be stored in airproof without silicon gel bag with clean air. For the sensors with long time storage but no electrify, they need long aging time for stbility before using.

#### 2.4 Long time exposed to adverse environment

No matter the sensors electrified or not, if exposed to adverse environment for long time, such as high humidity, high temperature, or high pollution etc, it will effect the sensors performance badly.

#### 2.5 Vibration

Continual vibration will result in sensors down-lead response then repture. In transportation or assembling line, pneumatic screwdriver/ultrasonic welding machine can lead this vibration.

#### 2.6 Concussion

If sensors meet strong concussion, it may lead its lead wire disconnected.

#### 2.7 Usage

For sensor, handmade welding is optimal way. If use wave crest welding should meet the following conditions:

2.7.1 Soldering flux: Rosin soldering flux contains least chlorine

2.7.2 Speed: 1-2 Meter/ Minute

2.7.3 Warm-up temperature:  $100\pm 20^{\circ}C$

2.7.4 Welding temperature:  $250\pm 10^{\circ}C$

2.7.5 1 time pass wave crest welding machine

If disobey the above using terms, sensors sensitivity will be reduced.

# MQ137 Semiconductor Sensor for Ammonia

Sensitive material of MQ137 gas sensor is SnO<sub>2</sub>, which with lower conductivity in clean air. When the target combustible gas exist, The sensor's conductivity is more higher along with the gas concentration rising. Please use simple electrocircuit, Convert change of conductivity to correspond output signal of gas concentration.

MQ137 gas sensor has high sensitivity to Ammonia, also to other organic amine. The sensor could be used to detect different gas which contains Ammonia, it is with low cost and suitable for different application.

### Character

- \* Good sensitivity to Ammonia
- \* Long life and low cost
- \* Simple drive circuit

### Application

- \* Domestic Ammonia detector
- \* Industrial Ammonia gas detector
- \* Portable gas detector

### Configuration

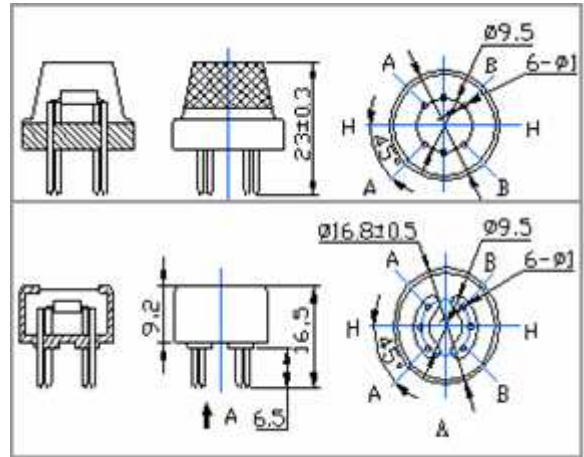

### Technical Data

#### Basic test loop

Model No.		MQ137	
Sensor Type		Semiconductor	
Standard Encapsulation		Bakelite (Black Bakelite)	
Detection Gas		Ammonia	
Concentration		5-500ppm (Ammonia)	
Circuit	Loop Voltage	V <sub>c</sub>	≤24V DC
	Heater Voltage	V <sub>H</sub>	5.0V±0.2V AC or DC
	Load Resistance	R <sub>L</sub>	Adjustable
Character	Heater Resistance	R <sub>H</sub>	31Ω±3Ω (Room Tem.)
	Heater consumption	P <sub>H</sub>	≤900mW
	Sensing Resistance	R <sub>s</sub>	2KΩ-15KΩ (in 50ppm NH <sub>3</sub> )
	Sensitivity	S	R <sub>s</sub> (in air)/R <sub>s</sub> (5000ppm CH <sub>4</sub> ) ≥ 5
	Slope	α	≤ 0.6 (R <sub>100ppm</sub> /R <sub>50ppm</sub> NH <sub>3</sub> )
Condition	Tem. Humidity	20°C ± 2°C; 65% ± 5% RH	
	Standard test circuit	V <sub>c</sub> : 5.0V ± 0.1V; V <sub>H</sub> : 5.0V ± 0.1V	
	Preheat time	Over 48 hours	

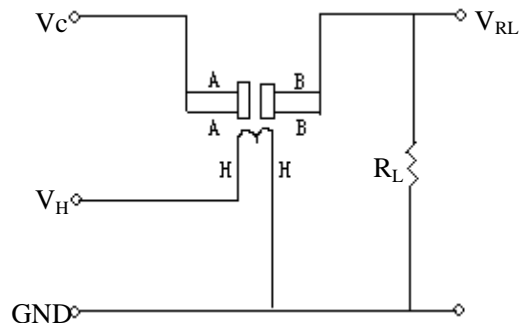

The above is basic test circuit of the sensor. The sensor need to be put 2 voltage, heater voltage (V<sub>H</sub>) and test voltage (V<sub>C</sub>). V<sub>H</sub> used to supply certified working temperature to the sensor, while V<sub>C</sub> used to detect voltage (V<sub>RL</sub>) on load resistance (R<sub>L</sub>) whom is in series with sensor. The sensor has light polarity, V<sub>c</sub> need DC power. V<sub>C</sub> and V<sub>H</sub> could use same power circuit with precondition to assure performance of sensor. In order to make the sensor with better performance, suitable R<sub>L</sub> value is needed:

Power of Sensitivity body (P<sub>s</sub>):  $P_s = V_c^2 \times R_s / (R_s + R_L)^2$

Resistance of sensor( $R_s$ ):  $R_s=(V_c/V_{RL}-1)\times R_L$

### Sensitivity Characteristics

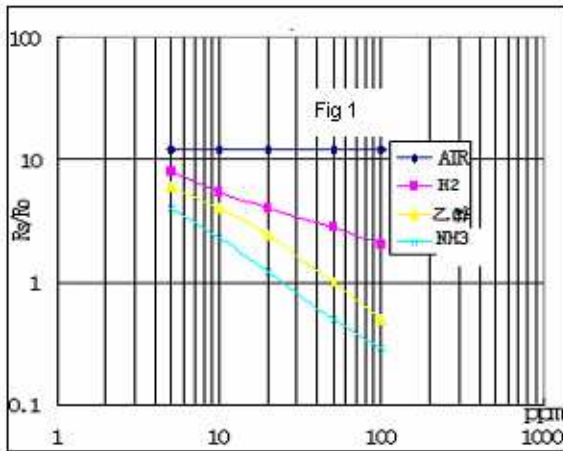

Fig.1 shows the typical sensitivity characteristics of the MQ137, ordinate means resistance ratio of the sensor ( $R_s/R_o$ ), abscissa is concentration of gases.  $R_s$  means resistance in different gases,  $R_o$  means resistance of sensor in 50ppm ethanol. All test are under standard test conditions.

P.S.: Sensitivity to smoke is ignite 10pcs cigarettes in 8m<sup>3</sup> room, and the output equals to 10ppm NH<sub>3</sub>

### Influence of Temperature/Humidity

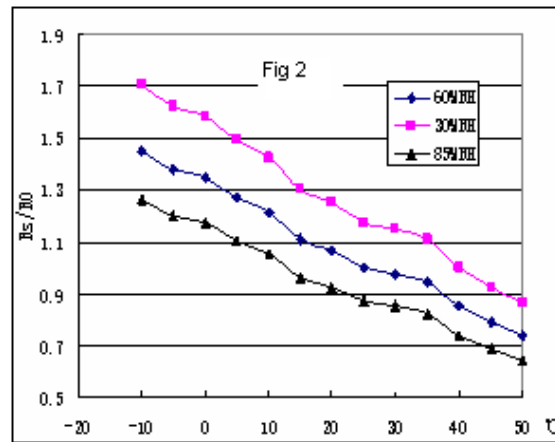
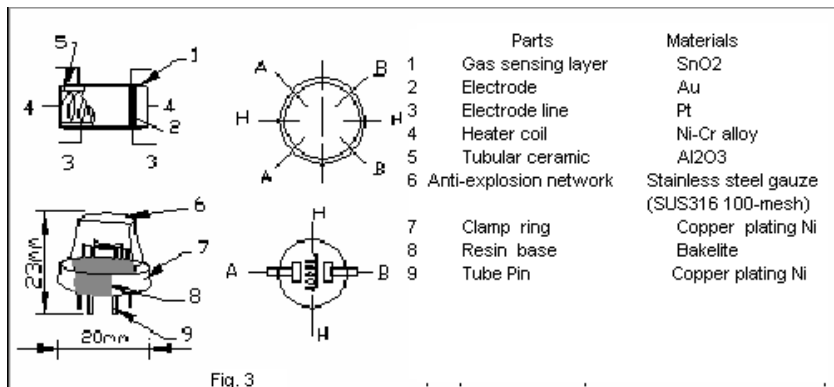

Fig.2 shows the typical temperature and humidity characteristics. Ordinate means resistance ratio of the sensor ( $R_s/R_o$ ),  $R_s$  means resistance of sensor in 50ppm NH<sub>3</sub> under different tem. and humidity.  $R_o$  means resistance of the sensor in environment of 50ppm NH<sub>3</sub>, 20°C/65%RH

### Structure and configuration



Structure and configuration of MQ137 gas sensor is shown as Fig. 3, sensor composed by micro AL<sub>2</sub>O<sub>3</sub> ceramic tube, Tin Dioxide (SnO<sub>2</sub>) sensitive layer, measuring electrode and heater are fixed into a crust made by plastic and stainless steel net. The heater provides necessary work conditions for work of sensitive components. The enveloped MQ-4 have 6 pin, 4 of them are used to fetch signals, and other 2 are used for providing heating current.

## **Notification**

### **1 Following conditions must be prohibited**

#### 1.1 Exposed to organic silicon steam

Organic silicon steam cause sensors invalid, sensors must be avoid exposing to silicon bond, fixture, silicon latex, putty or plastic contain silicon environment

#### 1.2 High Corrosive gas

If the sensors exposed to high concentration corrosive gas (such as  $H_2S$ ,  $SO_x$ ,  $Cl_2$ ,  $HCl$  etc), it will not only result in corrosion of sensors structure, also it cause sincere sensitivity attenuation.

#### 1.3 Alkali, Alkali metals salt, halogen pollution

The sensors performance will be changed badly if sensors be sprayed polluted by alkali metals salt especially brine, or be exposed to halogen such as fluorin.

#### 1.4 Touch water

Sensitivity of the sensors will be reduced when splattered or dipped in water.

#### 1.5 Freezing

Do avoid icing on sensor's surface, otherwise sensor would lose sensitivity.

#### 1.6 Applied voltage higher

Applied voltage on sensor should not be higher than stipulated value, otherwise it cause down-line or heater damaged, and bring on sensors' sensitivity characteristic changed badly.

#### 1.7 Voltage on wrong pins

For 6 pins sensor, if apply voltage on 1、3 pins or 4、6 pins, it will make lead broken, and without signal when apply on 2、4 pins

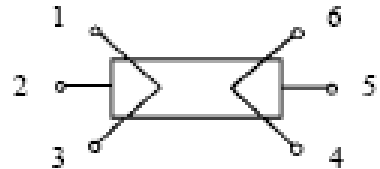

### **2 Following conditions must be avoided**

#### 2.1 Water Condensation

Indoor conditions, slight water condensation will effect sensors performance lightly. However, if water condensation on sensors surface and keep a certain period, sensor' sensitivity will be decreased.

#### 2.2 Used in high gas concentration

No matter the sensor is electrified or not, if long time placed in high gas concentration, if will affect sensors characteristic.

#### 2.3 Long time storage

The sensors resistance produce reversible drift if it's stored for long time without electrify, this drift is related with storage conditions. Sensors should be stored in airproof without silicon gel bag with clean air. For the sensors with long time storage but no electrify, they need long aging time for stbility before using.

#### 2.4 Long time exposed to adverse environment

No matter the sensors electrified or not, if exposed to adverse environment for long time, such as high humidity, high temperature, or high pollution etc, it will effect the sensors performance badly.

#### 2.5 Vibration

Continual vibration will result in sensors down-lead response then repture. In transportation or assembling line, pneumatic screwdriver/ultrasonic welding machine can lead this vibration.

#### 2.6 Concussion

If sensors meet strong concussion, it may lead its lead wire disconnected.

#### 2.7 Usage

For sensor, handmade welding is optimal way. If use wave crest welding should meet the following conditions:

2.7.1 Soldering flux: Rosin soldering flux contains least chlorine

2.7.2 Speed: 1-2 Meter/ Minute

2.7.3 Warm-up temperature:  $100\pm 20^{\circ}C$

2.7.4 Welding temperature:  $250\pm 10^{\circ}C$

2.7.5 1 time pass wave crest welding machine

If disobey the above using terms, sensors sensitivity will be reduced.

# MQ138 Semiconductor Sensor for Organic Steam

Sensitive material of MQ138 gas sensor is SnO<sub>2</sub>, which with lower conductivity in clean air. When the target Organic Steam exist, The sensor's conductivity is more higher along with the gas concentration rising. Please use simple electrocircuit, Convert change of conductivity to correspond output signal of gas concentration.

MQ138 gas sensor has high sensitivity to Toluene, Acetone, Ethanol and Formaldehyde, also to other organic steam. The sensor could be used to detect different organic steam, it is with low cost and suitable for different application.

## Character

- \* Good sensitivity to Organic Steam
- \* High sensitivity to Toluene, Acetone and Ethanol
- \* Long life and low cost
- \* Simple drive circuit

## Application

- \* Domestic Organic steam detector
- \* Industrial Organic steam detector
- \* Portable gas detector

## Configuration

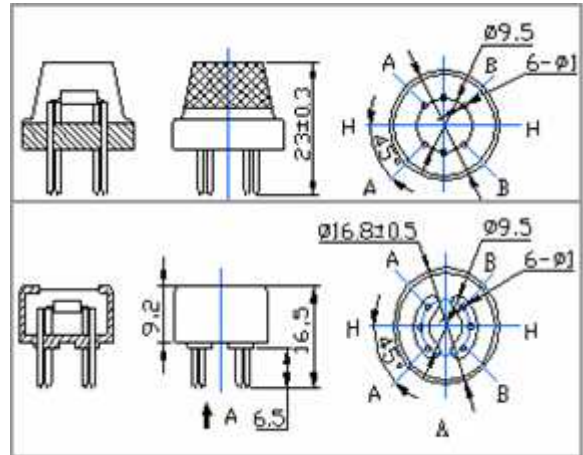

## Technical Data

Model No.		MQ138	
Sensor Type		Semiconductor	
Standard Encapsulation		Bakelite (Black Bakelite)	
Detection Gas		Toluene, Acetone, Ethanol, H <sub>2</sub>	
Concentration		5-500ppm	
Circuit	Loop Voltage	V <sub>c</sub>	≤24V DC
	Heater Voltage	V <sub>H</sub>	5.0V±0.2V AC or DC
	Load Resistance	R <sub>L</sub>	Adjustable
Character	Heater Resistance	R <sub>H</sub>	31Ω±3Ω (Room Tem.)
	Heater consumption	P <sub>H</sub>	≤900mW
	Sensing Resistance	R <sub>s</sub>	2KΩ-20KΩ(in 50ppm Toluene)
	Sensitivity	S	R <sub>s</sub> (in air)/R <sub>s</sub> (50ppm Toluene)≥3
	Slope	α	≤0.6≤0.6 (R <sub>100ppm</sub> /R <sub>50ppm</sub> Toluene)
Condition	Tem. Humidity	20°C±2°C; 65%±5%RH	
	Standard test circuit	V <sub>c</sub> : 5.0V±0.1V; V <sub>H</sub> : 5.0V±0.1V	
	Preheat time	Over 48 hours	

## Basic test loop

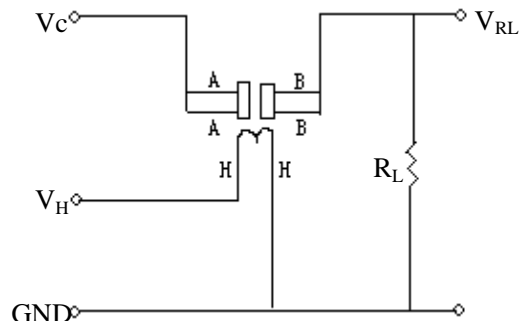

The above is basic test circuit of the sensor. The sensor need to be put 2 voltage, heater voltage(V<sub>H</sub>) and test voltage(V<sub>C</sub>). V<sub>H</sub> used to supply certified working temperature to the sensor, while V<sub>C</sub> used to detect voltage (V<sub>RL</sub>) on load resistance (R<sub>L</sub>) whom is in series with sensor. The sensor has light polarity, V<sub>c</sub> need DC power. V<sub>C</sub> and V<sub>H</sub> could use same power circuit with precondition to assure performance of sensor. In order to make the sensor with better performance, suitable R<sub>L</sub> value is needed:

$$\text{Power of Sensitivity body}(P_s): P_s = V_c^2 \times R_s / (R_s + R_L)^2$$

Resistance of sensor( $R_s$ ):  $R_s=(V_c/V_{RL}-1)\times R_L$

### Sensitivity Characteristics

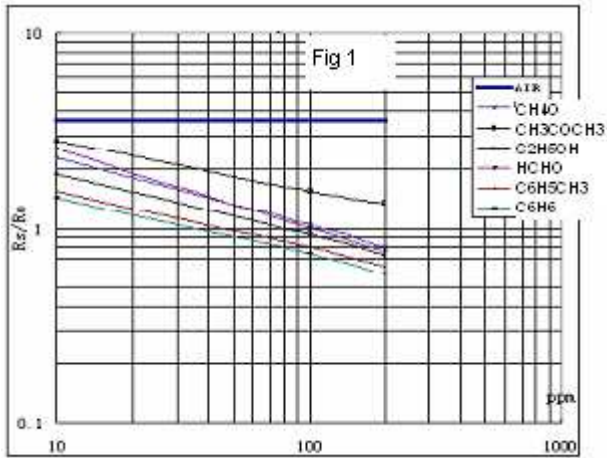

Fig.1 shows the typical sensitivity characteristics of the MQ138, ordinate means resistance ratio of the sensor ( $R_s/R_o$ ), abscissa is concentration of gases.  $R_s$  means resistance in different gases,  $R_o$  means resistance of sensor in 100ppm Toluene. All test are under standard test conditions.

### Influence of Temperature/Humidity

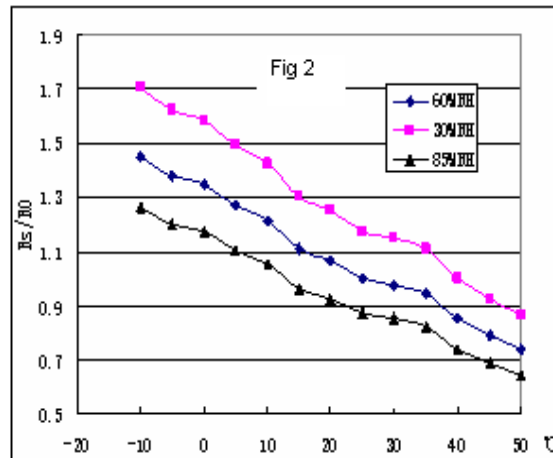
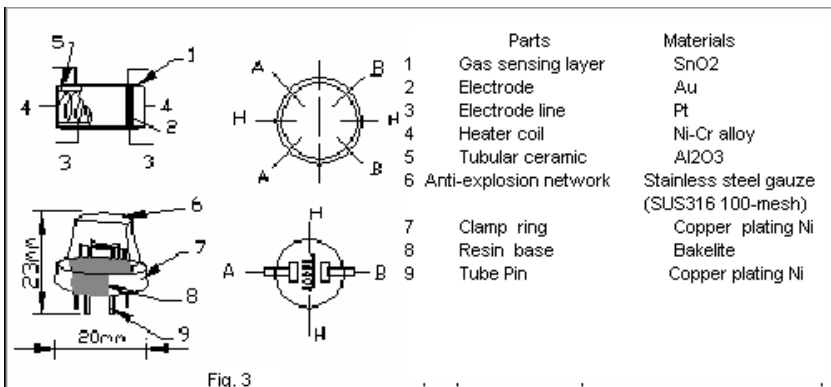

Fig.2 shows the typical temperature and humidity characteristics. Ordinate means resistance ratio of the sensor ( $R_s/R_o$ ),  $R_s$  means resistance of sensor in 100ppm Toluene under different tem. and humidity.  $R_o$  means resistance of the sensor in environment of 100ppm Toluene, 20°C/65%RH

### Structure and configuration



Structure and configuration of MQ138 gas sensor is shown as Fig. 3, sensor composed by micro AL<sub>2</sub>O<sub>3</sub> ceramic tube, Tin Dioxide (SnO<sub>2</sub>) sensitive layer, measuring electrode and heater are fixed into a crust made by plastic and stainless steel net. The heater provides necessary work conditions for work of sensitive components. The enveloped MQ-4 have 6 pin, 4 of them are used to fetch signals, and other 2 are used for providing heating current.



## **Notification**

### **1 Following conditions must be prohibited**

#### 1.1 Exposed to organic silicon steam

Organic silicon steam cause sensors invalid, sensors must be avoid exposing to silicon bond, fixture, silicon latex, putty or plastic contain silicon environment

#### 1.2 High Corrosive gas

If the sensors exposed to high concentration corrosive gas (such as  $H_2S$ ,  $SO_x$ ,  $Cl_2$ ,  $HCl$  etc), it will not only result in corrosion of sensors structure, also it cause sincere sensitivity attenuation.

#### 1.3 Alkali, Alkali metals salt, halogen pollution

The sensors performance will be changed badly if sensors be sprayed polluted by alkali metals salt especially brine, or be exposed to halogen such as fluorin.

#### 1.4 Touch water

Sensitivity of the sensors will be reduced when splattered or dipped in water.

#### 1.5 Freezing

Do avoid icing on sensor's surface, otherwise sensor would lose sensitivity.

#### 1.6 Applied voltage higher

Applied voltage on sensor should not be higher than stipulated value, otherwise it cause down-line or heater damaged, and bring on sensors' sensitivity characteristic changed badly.

#### 1.7 Voltage on wrong pins

For 6 pins sensor, if apply voltage on 1、3 pins or 4、6 pins, it will make lead broken, and without signal when apply on 2、4 pins

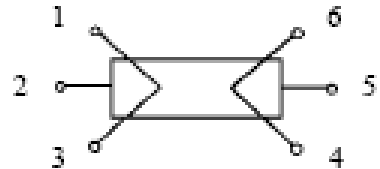

### **2 Following conditions must be avoided**

#### 2.1 Water Condensation

Indoor conditions, slight water condensation will effect sensors performance lightly. However, if water condensation on sensors surface and keep a certain period, sensor' sensitivity will be decreased.

#### 2.2 Used in high gas concentration

No matter the sensor is electrified or not, if long time placed in high gas concentration, if will affect sensors characteristic.

#### 2.3 Long time storage

The sensors resistance produce reversible drift if it's stored for long time without electrify, this drift is related with storage conditions. Sensors should be stored in airproof without silicon gel bag with clean air. For the sensors with long time storage but no electrify, they need long aging time for stbilty before using.

#### 2.4 Long time exposed to adverse environment

No matter the sensors electrified or not, if exposed to adverse environment for long time, such as high humidity, high temperature, or high pollution etc, it will effect the sensors performance badly.

#### 2.5 Vibration

Continual vibration will result in sensors down-lead response then repture. In transportation or assembling line, pneumatic screwdriver/ultrasonic welding machine can lead this vibration.

#### 2.6 Concussion

If sensors meet strong concussion, it may lead its lead wire disconnected.

#### 2.7 Usage

For sensor, handmade welding is optimal way. If use wave crest welding should meet the following conditions:

2.7.1 Soldering flux: Rosin soldering flux contains least chlorine

2.7.2 Speed: 1-2 Meter/ Minute

2.7.3 Warm-up temperature:  $100\pm 20^{\circ}C$

2.7.4 Welding temperature:  $250\pm 10^{\circ}C$

2.7.5 1 time pass wave crest welding machine

If disobey the above using terms, sensors sensitivity will be reduced.