

# WS12-8LCDA and WS15-8LCDA

## Transient Voltage Suppressor

### Features

- Transient protection for high-speed data lines to
- Protects eight I/O lines
- Low capacitance for high-speed interfaces
- High surge capability
- Low clamping voltage
- Solid-state silicon avalanche technology

### IEC COMPATIBILITY (EN61000-4)

- IEC 61000-4-2 (ESD)  $\pm 15\text{kV}$  (air),  $\pm 8\text{kV}$  (contact)
- IEC 61000-4-4 (EFT) 40A (5/50ns)
- IEC 61000-4-5 (Lightning) 0.5kV, 12A (8/20 $\mu\text{s}$ )

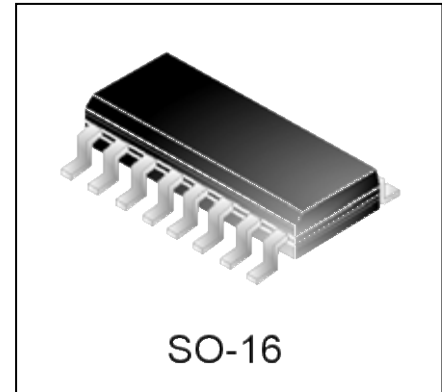

### Mechanical Characteristics

- JEDEC SO-16 package
- Molding compound flammability rating: UL 94V-0
- Marking : Part number, date code, logo
- Packaging : Tape and Reel per EIA 481
- RoHS Compliant

### Applications

- Multi-Mode Transceiver Protection
- WAN Equipment:
  - CSU/DSU, Multiplexers, Routers
  - ISP Equipment
  - Customer Premise Equipment
- Protection for any of the following interfaces:
  - RS-232 (V.28), RS-422 (V.11, X.21)
  - RS-449 (V.11/V.10)

### Circuit Diagram

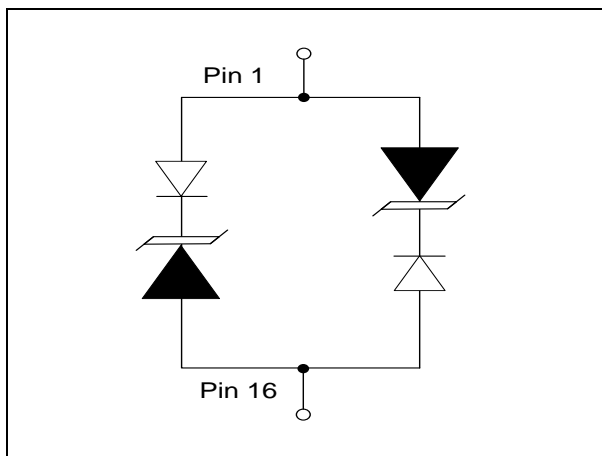

### Schematic & PIN Configuration

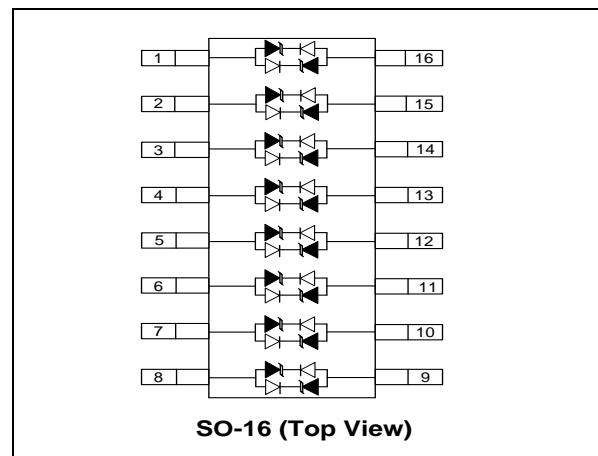

Absolute Maximum Rating			
Rating	Symbol	Value	Units
Peak Pulse Power ( $t_p = 8/20\mu s$ )	$P_{PK}$	500	Watts
Lead Soldering Temperature	$T_L$	260 (10 sec.)	°C
Operating Temperature	$T_J$	-55 to + 125	°C
Storage Temperature	$T_{STG}$	-55 to +150	°C

**Electrical Parameters (T=25°C)**

Symbol	Parameter
$I_{PP}$	Maximum Reverse Peak Pulse Current
$V_C$	Clamping Voltage @ $I_{PP}$
$V_{RWM}$	Working Peak Reverse Voltage
$I_R$	Maximum Reverse Leakage Current @ $V_{RWM}$
$V_{BR}$	Breakdown Voltage @ $I_T$
$I_T$	Test Current
$I_F$	Forward Current
$V_F$	Forward Voltage @ $I_F$

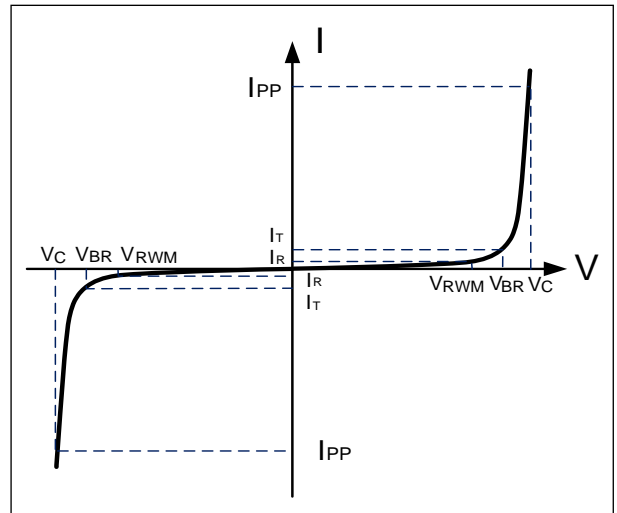

**Electrical Characteristics**

WS12-8LCDA						
Parameter	Symbol	Conditions	Minimum	Typical	Maximum	Units
Reverse Stand-Off Voltage	$V_{RWM}$				12	V
Reverse Breakdown Voltage	$V_{BR}$	$I_T=1mA$	13.3			V
Reverse Leakage Current	$I_R$	$V_{RWM}=12V, T=25^\circ C$			5	$\mu A$
Clamping Voltage	$V_C$	$I_{PP}=5A, t_p=8/20\mu s$			19	V
Clamping Voltage	$V_C$	$I_{PP}=20A, t_p=8/20\mu s$			26.6	V
Peak Pulse Current	$I_{PP}$	$t_p=8/20\mu s$			20	A
Junction Capacitance	$C_j$	Between I/O pins and Ground $V_R = 0V, f = 1MHz$		8	15	pF

<b>WS15-8LCDA</b>						
<b>Parameter</b>	<b>Symbol</b>	<b>Conditions</b>	<b>Minimum</b>	<b>Typical</b>	<b>Maximum</b>	<b>Units</b>
Reverse Stand-Off Voltage	$V_{RWM}$				15	V
Reverse Breakdown Voltage	$V_{BR}$	$I_T=1mA$	16.7			V
Reverse Leakage Current	$I_R$	$V_{RWM}=15V, T=25^{\circ}C$			5	$\mu A$
Clamping Voltage	$V_C$	$I_{PP}=1A, t_p=8/20\mu s$			24	V
Clamping Voltage	$V_C$	$I_{PP}=15A, t_p=8/20\mu s$			33	V
Peak Pulse Current	$I_{PP}$	$t_p=8/20\mu s$			15	A
Junction Capacitance	$C_j$	Between I/O pins and Ground $V_R = 0V, f = 1MHz$		8	15	pF

## Typical Characteristics

**Non-Repetitive Peak Pulse Power vs. Pulse Time**

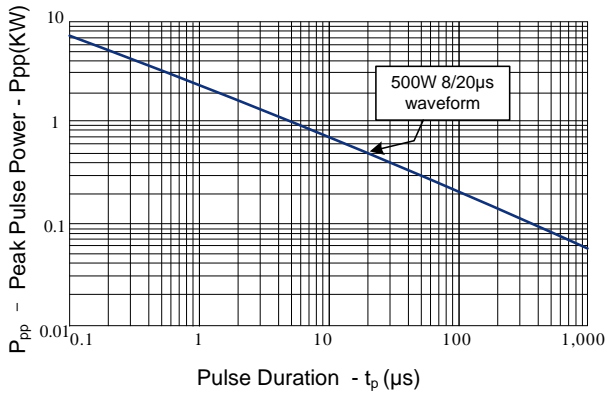

**Power Derating Curve**

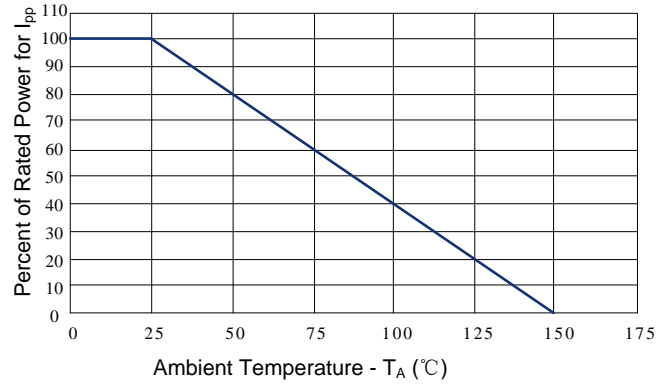

**Pulse Waveform**

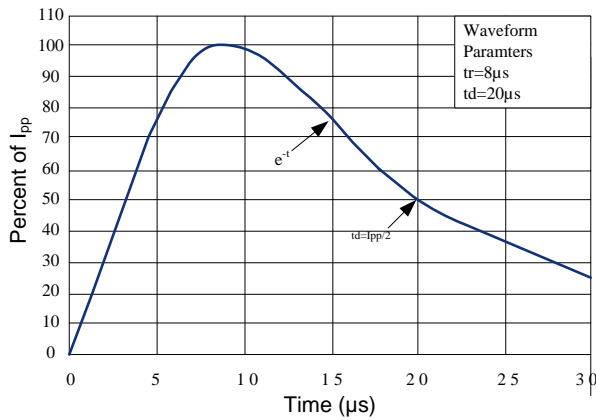

**Clamping Voltage vs. Peak Pulse Current**

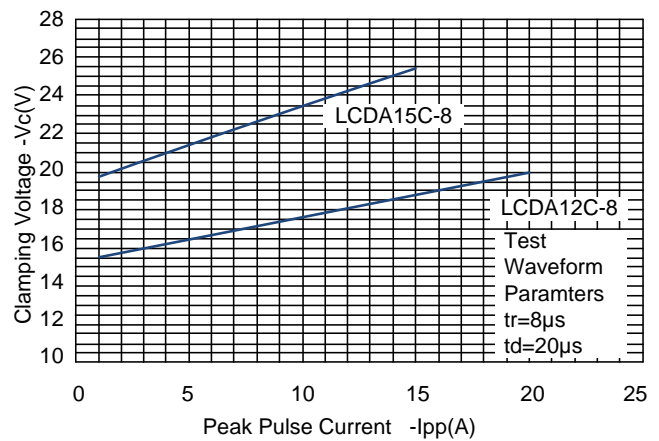

**LCDA12C-8 Capacitance vs. Reverse Voltage**

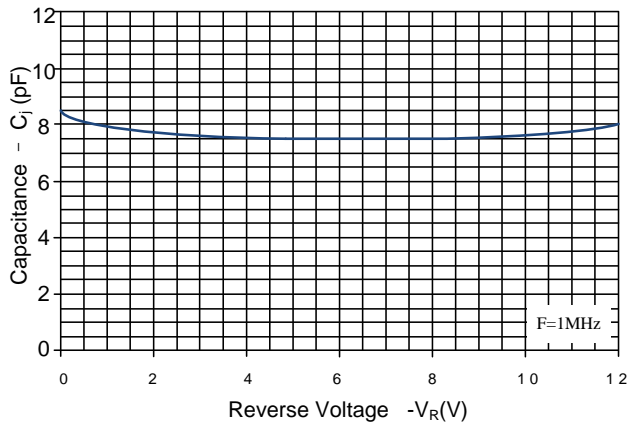

**LCDA15C-8 Capacitance vs. Reverse Voltage**

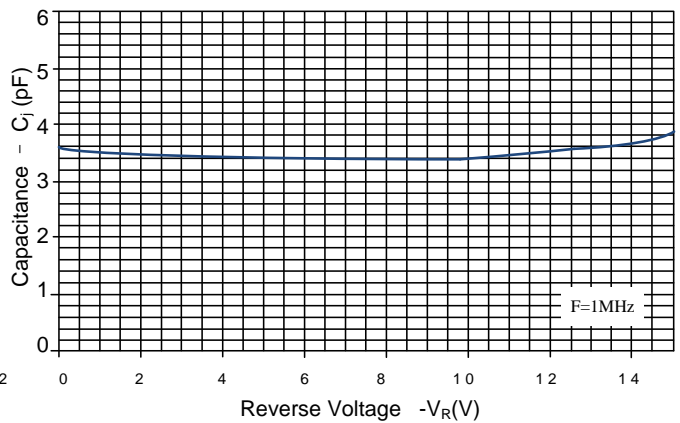

Outline Drawing – SO-16

### PACKAGE OUTLINE

**Notes**

- Controlling Dimensions in Millimeters (Angles In Degrees).
- Datums **A** And **B** To Be Determined At Datum Plane **H**.
- Dimensions "E1" And "D" Do Not Include Mold Flash, Protrusions Or Gate Burrs.
- Reference JEDEC STD MS-012, Variation AC.

SO-16

SYMBOL	MILLIMETER		INCHES	
	MIN	MAX	MIN	MAX
A	1.35	1.75	.053	.069
A1	0.10	0.25	.004	.010
A2	1.25	1.65	.049	.065
b	0.31	0.51	.012	.020
c	0.17	0.25	.007	.010
D	9.80	10.00	.386	.394
E1	3.80	4.00	.150	.157
E	6.00 BSC		.236 BSC	
e	1.27 BSC		.050 BSC	
h	0.25	0.50	.010	.020
L	0.40	1.04	.016	.041
L1	(1.04)		(.041)	
N	16		16	
theta 1	0°	8°	0°	8°
aaa	0.10		.004	
bbb	0.25		.010	
ccc	0.20		.008	

---

**NOTES:**

- This Land Pattern Is For Reference Purposes Only. Consult Your Manufacturing Group To Ensure Your Company's Manufacturing Guidelines Are Met.
- Reference IPC-SM-782A, RLP NO. 304A.

SYMBOL	MILLIMETERS	INCHES
	C	(5.20)
G	3.00	.118
P	1.27	.050
X	0.60	.024
Y	2.20	.087
Z	7.40	.291

Marking Codes

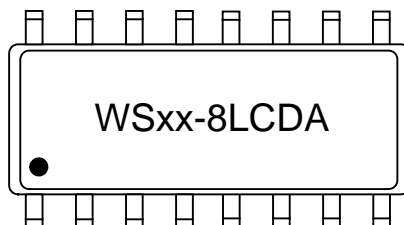

XX=Reverse Stand-Off Voltage