

WS05M2T through WS36M2T

Transient Voltage Suppressor

Features

- 300 watts peak pulse power ($t_p = 8/20\mu s$)
- ESD Protection > 40 kilovolts
- Protects one bidirectional line or two unidirectional lines
- Working Voltages: 5V, 12V, 15V, 24V and 36V
- Low clamping voltages

IEC COMPATIBILITY (EN61000-4)

- IEC 61000-4-2 (ESD) $\pm 15kV$ (air), $\pm 8kV$ (contact)
- IEC 61000-4-4 (EFT) 40A (5/50ns)
- IEC 61000-4-5 (Lightning) 18A (8/20 μs)

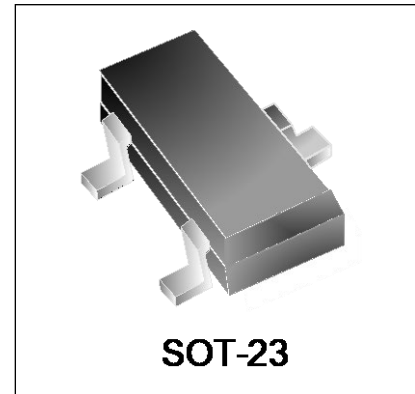

Mechanical Characteristics

- JEDEC SOT23 package
- Molding compound flammability rating: UL 94V-0
- Marking: Marking Code
- Packaging: Tape and Reel per EIA 481
- RoHS/WEEE Compliant

Applications

- RS-232, RS-422 & RS-485
- Cellular Handsets and Accessories
- Control & Monitoring Systems
- Portable Electronics
- Set-Top Box
- Servers, Notebook, and Desktop PC
- Wireless Bus Protection

Circuit Diagram

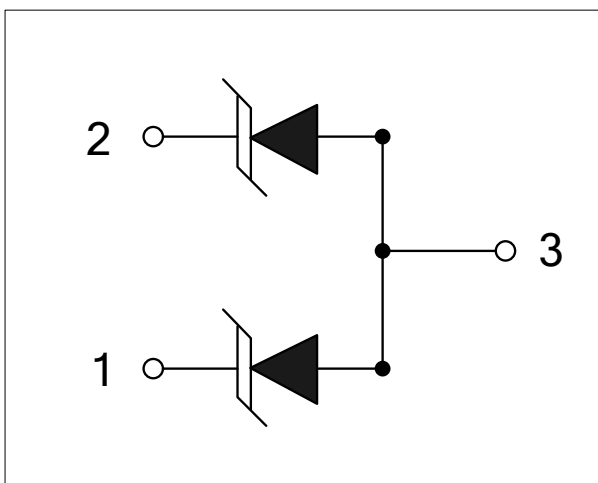

Schematic & PIN Configuration

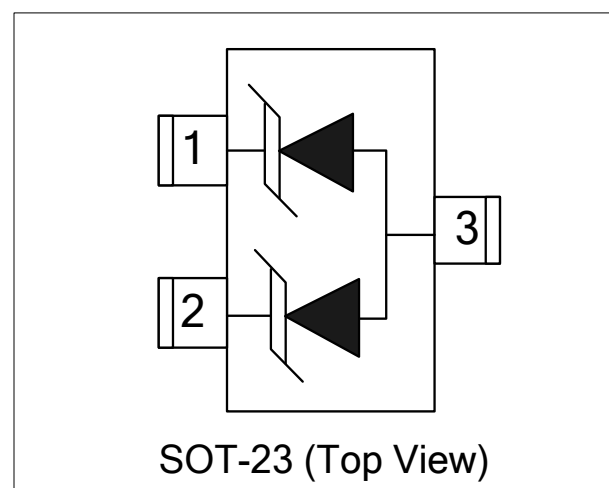

Absolute Maximum Rating			
Rating	Symbol	Value	Units
Peak Pulse Power ($t_p=8/20\mu s$)	P_{PP}	300	Watts
Lead Soldering Temperature	T_L	260(10sec)	°C
Operating Temperature	T_J	-55 to + 125	°C
Storage Temperature	T_{STG}	-55 to +150	°C

Electrical Parameters (T=25°C)

Symbol	Parameter
I_{PP}	Maximum Reverse Peak Pulse Current
V_C	Clamping Voltage @ I_{PP}
V_{RWM}	Working Peak Reverse Voltage
I_R	Maximum Reverse Leakage Current @ V_{RWM}
V_{BR}	Breakdown Voltage @ I_T
I_T	Test Current
I_F	Forward Current
V_F	Forward Voltage @ I_F

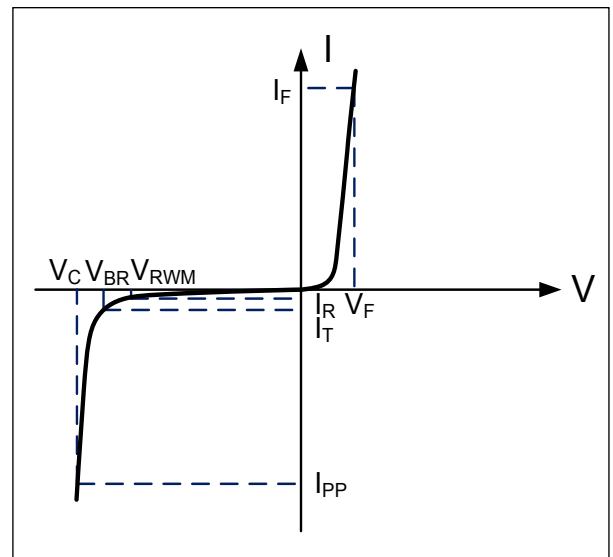

Electrical Characteristics

WS05M2T						
Parameter	Symbol	Conditions	Minimum	Typical	Maximum	Units
Reverse Stand-Off Voltage	V_{RWM}				5	V
Reverse Breakdown Voltage	V_{BR}	$I_T=1mA$	6			V
Reverse Leakage Current	I_R	$V_{RWM}=5V, T=25°C$			1	μA
Peak Pulse Current	I_{PP}	$t_p = 8/20\mu s$			18	A
Clamping Voltage	V_C	$I_{PP}=1A, t_p=8/20\mu s$			9.8	V
Maximum Clamping Voltage	V_C	$I_{PP}=18A, t_p=8/20\mu s$			16.7	V
Junction Capacitance	C_j	Pin 1 to 2 $V_R = 0V, f = 1MHz$		100		pF
Junction Capacitance	C_j	Pin 1 to 3 and Pin 2 to 3 $V_R = 0V, f = 1MHz$		150		pF

WS12M2T						
Parameter	Symbol	Conditions	Minimum	Typical	Maximum	Units
Reverse Stand-Off Voltage	V_{RWM}				12	V
Reverse Breakdown Voltage	V_{BR}	$I_T=1mA$	13.3			V
Reverse Leakage Current	I_R	$V_{RWM}=12V, T=25^{\circ}C$			1	μA
Peak Pulse Current	I_{PP}	$t_p=8/20\mu s$			12	A
Clamping Voltage	V_C	$I_{PP}=1A, t_p=8/20\mu s$			19	V
Maximum Clamping Voltage	V_C	$I_{PP}=12A, t_p=8/20\mu s$			25	V
Junction Capacitance	C_j	Pin 1 to 2 $V_R=0V, f=1MHz$		30		pF
Junction Capacitance	C_j	Pin 1 to 3 and Pin 2 to 3 $V_R=0V, f=1MHz$		50		pF
WS15M2T						
Parameter	Symbol	Conditions	Minimum	Typical	Maximum	Units
Reverse Stand-Off Voltage	V_{RWM}				15	V
Reverse Breakdown Voltage	V_{BR}	$I_T=1mA$	16.7			V
Reverse Leakage Current	I_R	$V_{RWM}=15V, T=25^{\circ}C$			1	μA
Peak Pulse Current	I_{PP}	$t_p=8/20\mu s$			10	A
Clamping Voltage	V_C	$I_{PP}=1A, t_p=8/20\mu s$			24	V
Maximum Clamping Voltage	V_C	$I_{PP}=10A, t_p=8/20\mu s$			30	V
Junction Capacitance	C_j	Pin 1 to 2 $V_R=0V, f=1MHz$		25		pF
Junction Capacitance	C_j	Pin 1 to 3 and Pin 2 to 3 $V_R=0V, f=1MHz$		40		pF
WS24M2T						
Parameter	Symbol	Conditions	Minimum	Typical	Maximum	Units
Reverse Stand-Off Voltage	V_{RWM}				24	V
Reverse Breakdown Voltage	V_{BR}	$I_T=1mA$	26.7			V
Reverse Leakage Current	I_R	$V_{RWM}=24V, T=25^{\circ}C$			1	μA
Peak Pulse Current	I_{PP}	$t_p=8/20\mu s$			5	A
Clamping Voltage	V_C	$I_{PP}=1A, t_p=8/20\mu s$			43	V
Maximum Clamping Voltage	V_C	$I_{PP}=5A, t_p=8/20\mu s$			60	V
Junction Capacitance	C_j	Pin 1 to 2 $V_R=0V, f=1MHz$		20		pF
Junction Capacitance	C_j	Pin 1 to 3 and Pin 2 to 3 $V_R=0V, f=1MHz$		30		pF

WS36M2T						
Parameter	Symbol	Conditions	Minimum	Typical	Maximum	Units
Reverse Stand-Off Voltage	V_{RWM}				36	V
Reverse Breakdown Voltage	V_{BR}	$I_T=1mA$	40			V
Reverse Leakage Current	I_R	$V_{RWM}=36V, T=25^\circ C$			1	μA
Peak Pulse Current	I_{PP}	$t_p=8/20\mu s$			4	A
Clamping Voltage	V_C	$I_{PP}=1A, t_p=8/20\mu s$			60	V
Maximum Clamping Voltage	V_C	$I_{PP}=4A, t_p=8/20\mu s$			75	V
Junction Capacitance	C_j	Pin 1 to 2 $V_R=0V, f=1MHz$		20		pF
Junction Capacitance	C_j	Pin 1 to 3 and Pin 2 to 3 $V_R=0V, f=1MHz$		26		pF

Typical Characteristics

Peak Pulse Power vs. Pulse Time

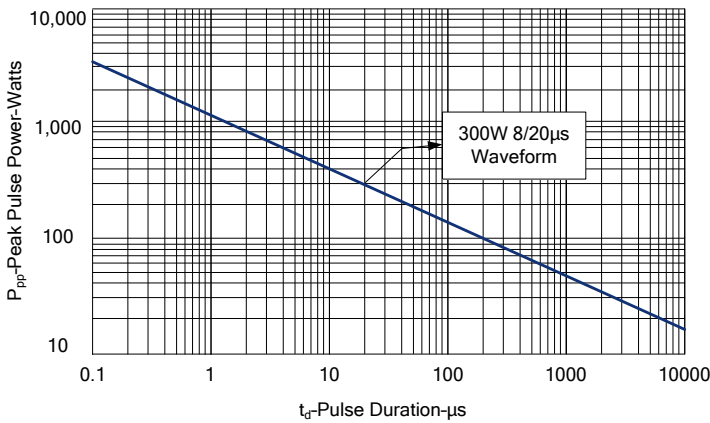

Power Derating Curve

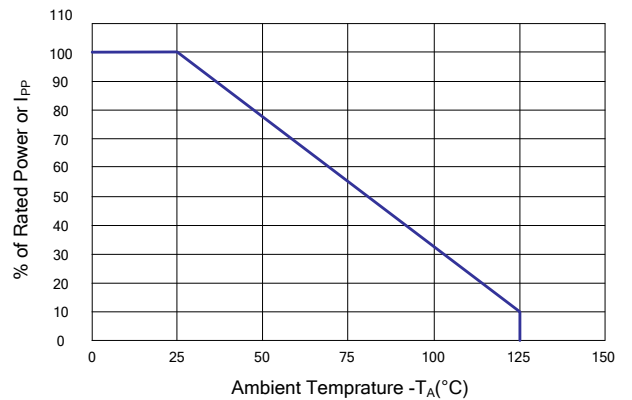

Pulse Waveform

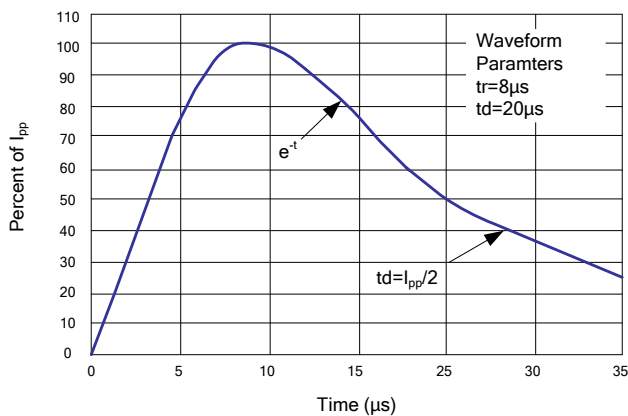

ESD Pulse Waveform (Per IEC 61000-4-2)

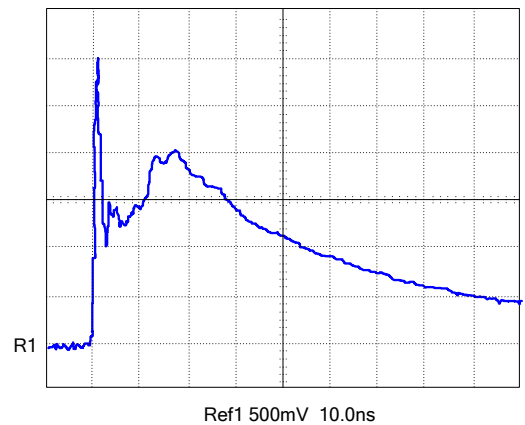

Outline Drawing – SOT-23

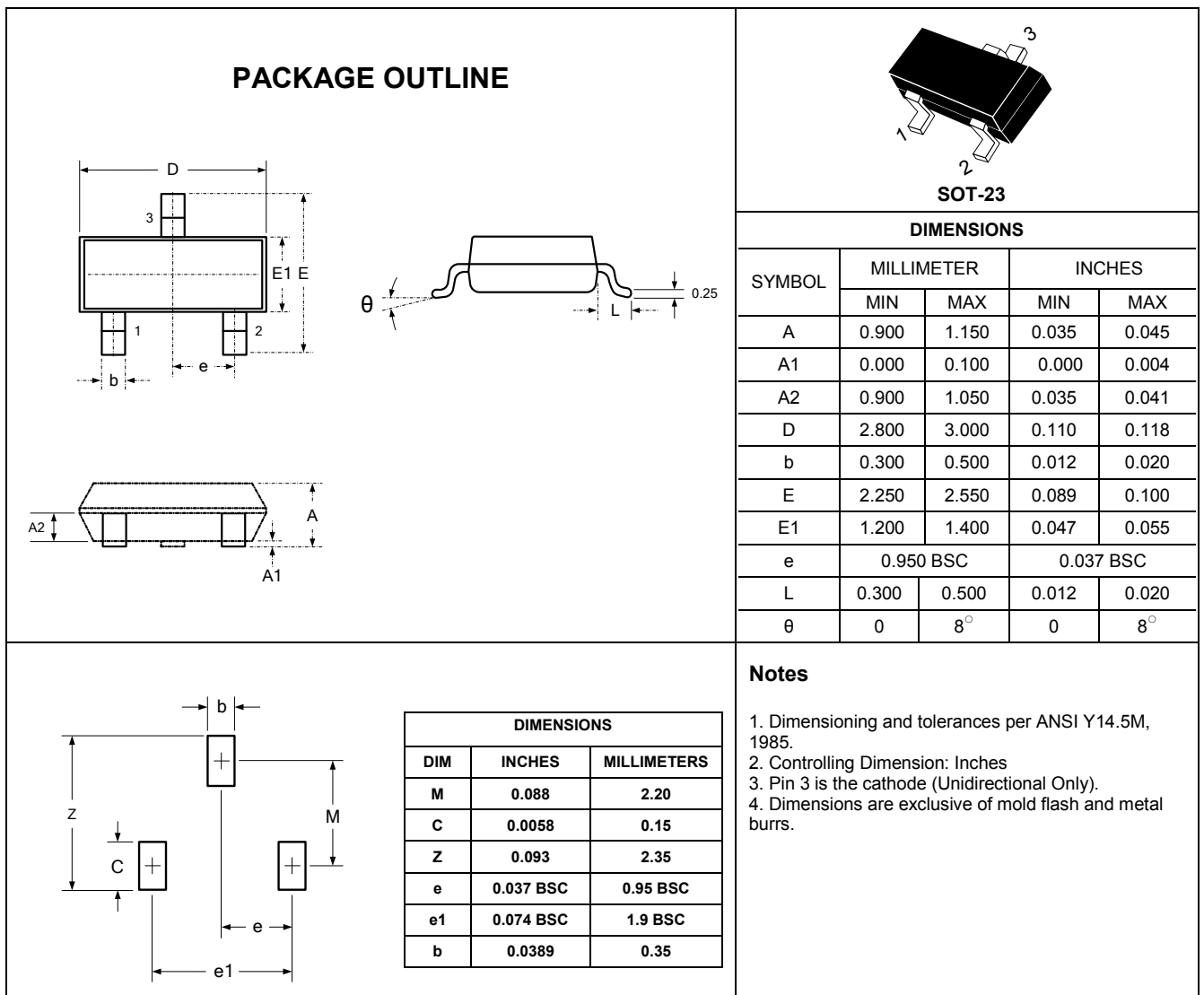

Marking Codes

Part Number	WS05M2T	WS12M2T	WS15M2T	WS24M2T	WS36M2T
Marking Code	5M2	AM2	BM2	CM2	DM2