

1. Scope

The specification is fit for ceramic resonator 1.84-8.00MHz.

2. Part NO: ZTTCC ..MG

3. Electrical Characteristics

No.	Item	Characteristics
3-1	Oscillate Frequency (MHz)	1.84-8.00
3.2	Frequency Tolerance max	±0.5%
3.3	Resonant Impedance max (Ω)	100
3.4	Built – in Capacitance (PF)	30
3.5	Insulate Resistance min (MΩ)	100
3.6	Withstanding Voltage D.C (V)	100 (max 5 sec)
3.7	Voltage (1) D.C Voltage max (V) (2) Input Voltage max (V)	6 15Vp-p
3.8	Temp characteristics of Oscillate frequency max	±0.3%
3.9	Operating Temp Range (°C)	-20 ~ +80
3.10	Storage Temp (°C)	-55 ~ +85

4. Test Circuit

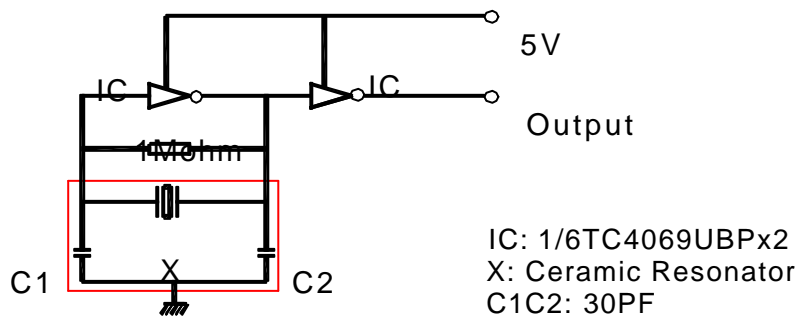

5. Dimension

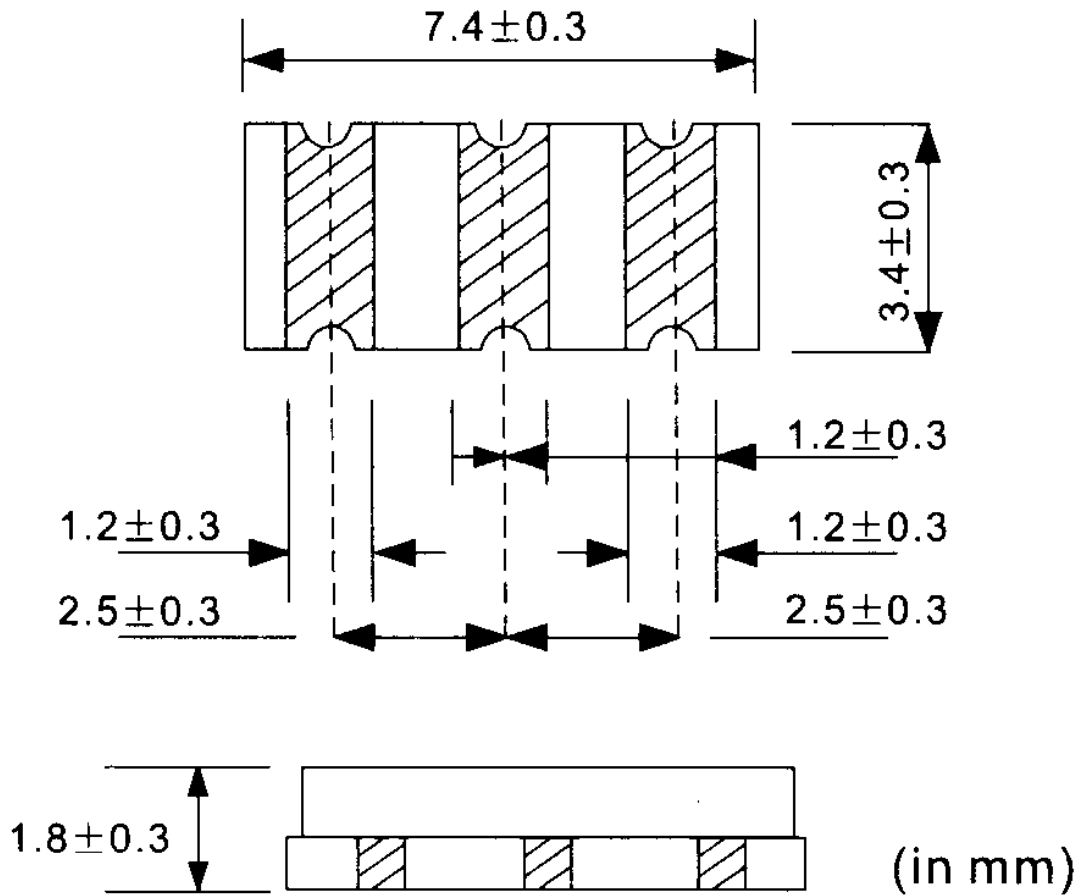

6. Physical and Environmental Characteristics

No	Item	Condition of Test	Performance Requirements
6.1	Humidity	Keep the resonator at $40 \pm 2^\circ\text{C}$ and 90-95% RH for 96 ± 4 hours. Then release the resonator into the room condition for 1 hour prior to the measurement.	It shall fulfill the specifications in Table 1.
6.2	Vibration	Subject the resonator to vibration for 2 hours each in x,y and z axis with the amplitude of 1.5mm, the frequency shall be varied uniformly between the limits of 10-55Hz	It shall fulfill the specifications in Table 1.
6.3	Mechanical Shock	Drop the resonator randomly onto a concrete floor from the height of 100 cm 3 times.	It shall fulfill the specifications in Table 1.
6.4	Soldering Test	Passed through the re-flow oven under the following condition and left at room temperature for 1 hour before measurement.	It shall fulfill the specifications in Table 1.



		Temperature at surface of the substrate	Time	
		Preheat $150\pm 5^{\circ}\text{C}$	60 ± 10 sec.	
		Peak $240\pm 5^{\circ}\text{C}$	10 ± 3 sec.	
6.5	Solder Ability	Dip the resonator terminals into the solder bath at $230\pm 5^{\circ}\text{C}$ for 3 ± 0.5 sec.		More than 95% of the terminal surface shall be covered.
6.6	High Temperature Exposure	Subject the resonator to $80\pm 5^{\circ}\text{C}$ for 96 ± 4 hours. Then release the resonator into the room conditions for 1 hour prior to the measurement.		It shall fulfill the specifications in Table 1.
6.7	Low Temperature	Subject the resonator to $-20\pm 5^{\circ}\text{C}$ for 96 ± 4 hours. Then release the resonator into the room conditions for 1 hour prior to the measurement.		It shall fulfill the specifications in Table 1.
6.8	Temperature Cycling	Subject the resonator to -20°C for 30 minutes followed by a high temperature of 85°C for 30 min. Cycling shall be repeated 5 times with a transfer time of 15 second at the room condition for 1 hour prior to the measurement.		It shall fulfill the specifications in Table 1.

TABLE1

Item	Specification
Oscillation Frequency Change	$\Delta F/F_0 \leq 0.3\%$ max
Resonant Impedance	$\Delta R_0 \leq \pm 10$ Ohm

7.

RECOMMENDED REFLOW SOLDERING STANDARD CONDITIONS

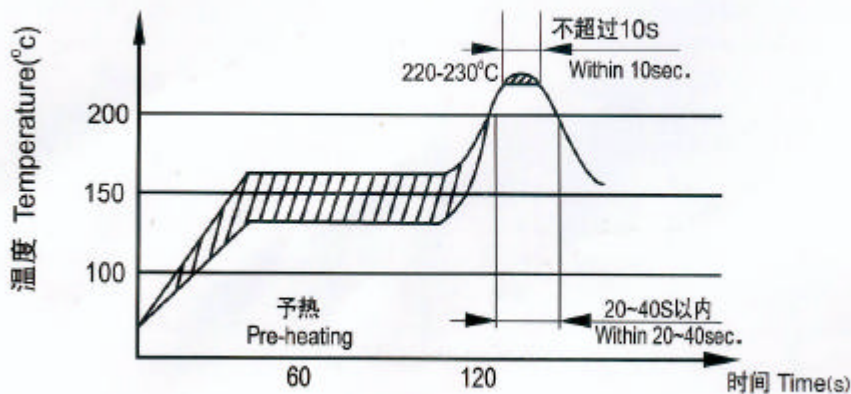

8. Packing

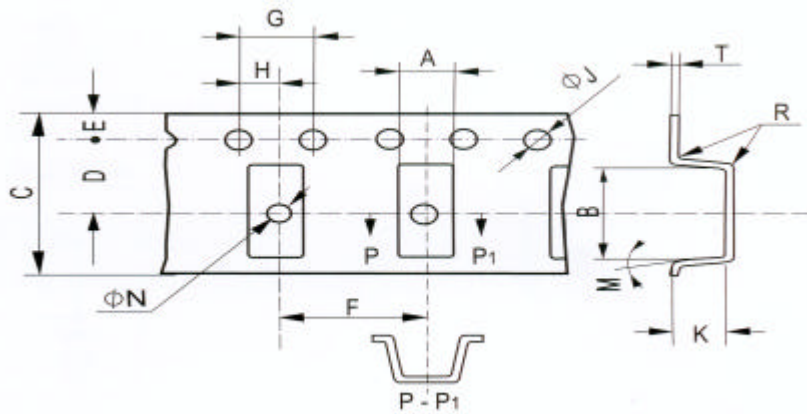

Tape Dimension (mm)

	A ±0.2	B ±0.2	C ±0.3	D ±0.1	E ±0.1	F ±0.1	G ±0.1	H ±0.1	∅J ±0.1	∅N ±0.1	M max	R max	K ±0.2	T ±0.1
MG	3.8	7.8	16.0	7.5	1.75	8.0	4.0	2.0	1.5	1.6	10 [°]	0.3	2.1	0.3
MT	5.0	4.4	12.0	5.5									1.8	
MX	3.4	4.0	12.0	5.5									1.3	

Standard Package: 4Kpcs / reel